

---

# SAMPLE OF THE STUDY MATERIAL

## PART OF CHAPTER - 1

### NETWORK METHODOLOGY

#### 1.1. Passive Components

A **passive component**, depending on field, may be either a component that consumes (but does not produce) energy or a component that is incapable of power gain . The passive circuit elements resistance R, inductance L and capacitance C are defined by the manner in which voltage and current are related for the individual element. The table below summarizes the voltage-current (V-I) relation, instantaneous power (P) consumption and energy stored in the period  $[t_1, t_2]$  for each of above elements .

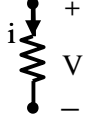
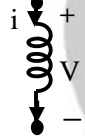

The **electrical resistance** of an electrical element measures its opposition to the passage of an electric current; the inverse quantity is **called conductance**. The resistance of an object is defined as the ratio of voltage across it to current through it:

$$R = \frac{V}{I}$$

**Inductance** is the property of an electrical circuit causing voltage to be generated proportional to the rate of change in current in a circuit. Inductance is caused by the magnetic field generated by electric currents according to Ampere's law.

**Capacitance** is the ability of a body to hold an electrical charge. Physically, a capacitor is two electrical conductors separated by a non-conducting (or very high resistance) medium between the conductors.

Table 1.1. Voltage –Current relation of network elements

SL. No	Circuit element	Symbol in electric circuit	Units	Voltage – current relation	Instantaneous power , P	Energy stored / dissipated in $[t_1, t_2]$
1	Resistance, R		Ohm ( $\Omega$ )	$V = i R$ ( ohm's law)	$V i = i^2 R$	$i^2 R (t_2 - t_1)$
2	Inductance, L		Henry ( H )	$V = L \frac{di}{dt}$	$L i \frac{di}{dt}$	$\frac{1}{2} L ( i_2^2 - i_1^2 )$
3	Capacitance, C		Farad ( F )	$i = C \frac{dv}{dt}$	$C v \frac{dv}{dt}$	$\frac{1}{2} C ( v_2^2 - v_1^2 )$

In the above table, if  $i_m$  is the current at instant  $m$  and  $V_m$  is the voltage at instant  $m$ , total energy dissipated in a resistor (R) in  $[t_1, t_2] = \int_{t_1}^{t_2} v_t \cdot i_t dt = \int_{t_1}^{t_2} i_t^2 R dt$

### 1.2. Series and parallel connection of circuit elements

Figure below summarizes equivalent resistance /inductance /capacitance for different combinations of network elements.

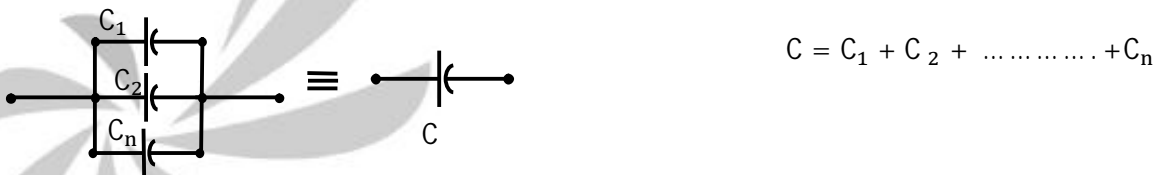
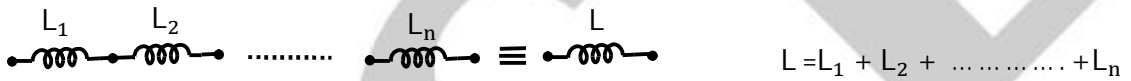
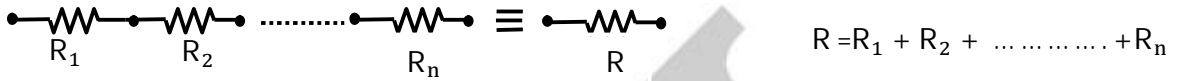


Fig1.1 Series and parallel connection of circuit elements

### 1.3. Voltage / Current relation in series / parallel connection of resistor

Figures below summarizes voltage/current relations in series and parallel connection of resistors.

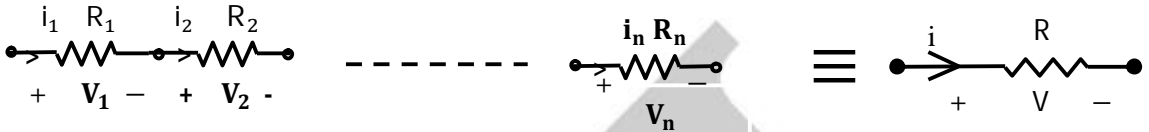


Fig1.2 Series connection of resistor

For series connection of resistors,  $i_1 = i_2 = \dots \dots i_n = i$

$$V = \sum v_i, \quad \therefore v_i \times \frac{R_i}{(\sum_{i=1}^n R_i)} \quad \forall i = 1, \dots, n$$

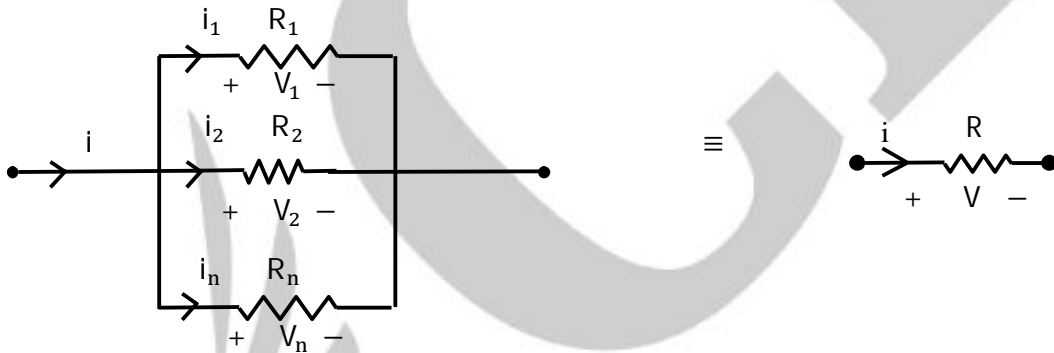


Fig 1.3 Parallel combination of resistors

For parallel connection of resistors,

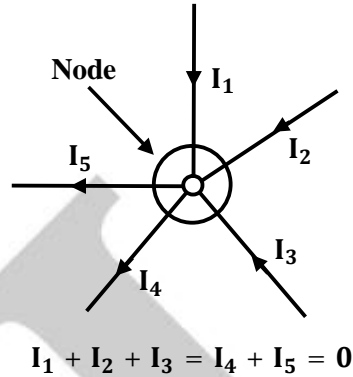
$$i = \sum i_i, \quad i_i = i \times \frac{\frac{1}{R_i}}{\left(\sum \frac{1}{R_i}\right)} \quad \forall i = 1, \dots, n$$

$$V_1 = V_2 = \dots \dots \dots = V_n = V$$

### 1.4. Kirchoff's Current Law ( KCL)

KCL, states that the "total current or charge entering a junction or node is exactly equal to the charge leaving the node as it has no other place to go except to leave, as no charge is lost within the node". In other words the algebraic sum of ALL the currents entering and leaving a node must be equal to zero,  $I_{(exiting)} + I_{(entering)} = 0$ . This idea by Kirchoff is known as the **Conservation of Charge**.

Currents Entering the Node  
=  
Currents Leaving the Node



**Fig. 1.4 Kirchoff Current Law**

Here, the three currents entering the node,  $I_1, I_2, I_3$  are all positive in value and the two currents leaving the node,  $I_4$  and  $I_5$  are negative in value. Then this means we can also rewrite the equation as;

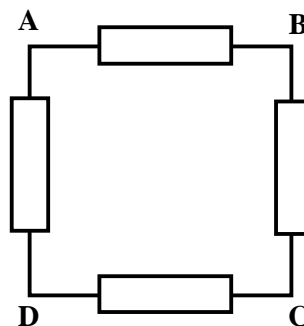
$$I_1 + I_2 + I_3 - I_4 - I_5 = 0$$

The term **Node** in an electrical circuit generally refers to a connection or junction of two or more current carrying paths or elements such as cables and components. Also for current to flow either in or out of a node a closed circuit path must exist. We can use Kirchoff's current law when analysing parallel circuits.

### 1.5. Kirchoff's Voltage Law (KVL)

KVL, states that "in any closed loop network, the total voltage around the loop is equal to the sum of all the voltage drops within the same loop" which is also equal to zero. In other words the algebraic sum of all voltages within the loop must be equal to zero. This idea by Kirchoff is known as the **Conservation of Energy**.

The sum of the voltage drops around the loop equal zero



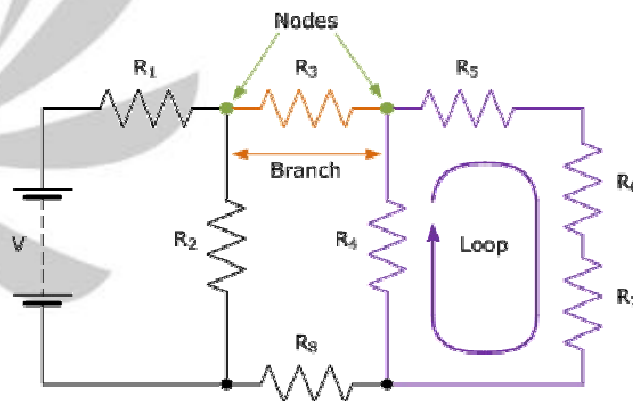
**Fig. 1.5 Kirchoff Voltage Law**

$$V_{AB} + V_{BC} + V_{CD} + V_{DA} = 0$$

Starting at any point in the loop continue in the **same direction** noting the direction of all the voltage drops, either positive or negative, and returning back to the same starting point. It is important to maintain the same direction either clockwise or anti-clockwise or the final voltage sum will not be equal to zero. We can use Kirchoff's voltage law when analysing series circuits.

When analysing either DC circuits or AC circuits using **Kirchoff's Circuit Laws** a number of definitions and terminologies are used to describe the parts of the circuit being analysed such as: node, paths, branches, loops and meshes. These terms are used frequently in circuit analysis so it is important to understand them.

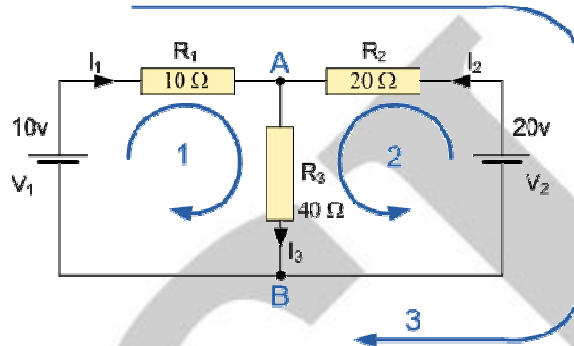
- **Circuit** - a circuit is a closed loop conducting path in which an electrical current flows.
- **Path** - a line of connecting elements or sources with no elements or sources included more than once.
- **Node** - a node is a junction, connection or terminal within a circuit where two or more circuit elements are connected or joined together giving a connection point between two or more branches. A node is indicated by a dot.
- **Branch** - a branch is a single or group of components such as resistors or a source which are connected between two nodes.
- **Loop** - a loop is a simple closed path in a circuit in which no circuit element or node is encountered more than once.
- **Mesh** - a mesh is a single open loop that does not have a closed path. No components are inside a mesh.
- Components are connected in series if they carry the same current.
- Components are connected in parallel if the same voltage is across them.



**Fig. 1.6 Network Methodology Representation**

**Example No.1**

Find the current flowing in the  $40\Omega$  Resistor,  $R_3$

**Fig. 1.7**

The circuit has 3 branches, 2 nodes (A and B) and 2 independent loops.

Using **Kirchoff's Current Law, KCL** the equations are given as;

$$\text{At node A : } I_1 + I_2 = I_3$$

$$\text{At node B : } I_3 = I_1 + I_2$$

Using **Kirchoff's Voltage Law, KVL** the equations are given as;

$$\text{Loop 1 is given as : } 10 = R_1 \times I_1 + R_3 \times I_3 = 10I_1 + 40I_3$$

$$\text{Loop 2 is given as : } 20 = R_2 \times I_2 + R_3 \times I_3 = 20I_2 + 40I_3$$

$$\text{Loop 3 is given as : } 10 - 20 = 10I_1 - 20I_2$$

As  $I_3$  is the sum of  $I_1 + I_2$  we can rewrite the equations as;

$$\text{Eq. No 1 : } 10 = 10I_1 + 40(I_1 + I_2) = 50I_1 + 40I_2$$

$$\text{Eq. No 2 : } 20 = 20I_1 + 40(I_1 + I_2) = 40I_1 + 60I_2$$

We now have two "**Simultaneous Equations**" that can be reduced to give us the value of both  $I_1$  and  $I_2$

Substitution of  $I_1$  in terms of  $I_2$  gives us the value of  $I_1$  as  $-0.143$  Amps

Substitution of  $I_2$  in terms of  $I_1$  gives us the value of  $I_2$  as  $+0.429$  Amps

$$\text{As : } I_3 = I_1 + I_2$$

The current flowing in resistor  $R_3$  is given as :  $-0.143 + 0.429 = 0.286$  Amps

and the voltage across the resistor  $R_3$  is given as :  $0.286 \times 40 = 11.44$  volts

The negative sign for  $I_1$  means that the direction of current flow initially chosen was wrong, but never the less still valid. In fact, the 20v battery is charging the 10v battery.

## 1.6. Circuit Analysis

All network circuits can be solved using **Kirchoff's Circuit Laws**. While Kirchoff's Laws give us the basic method for analysing any complex electrical circuit, there are different ways of improving upon this method by using **Mesh Current Analysis** or **Nodal Voltage Analysis** that results in a lessening of the math's involved and when large networks are involved this reduction in maths can be a big advantage.

For example, consider the circuit from the previous example.

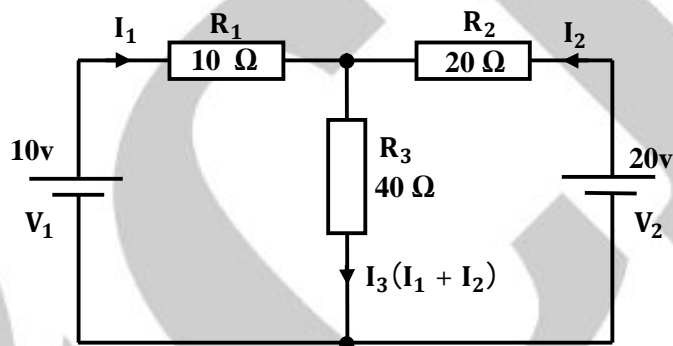


Fig. 1.8

One simple method of reducing the amount of math's involved is to analyse the circuit using Kirchoff's Current Law equations to determine the currents,  $I_1$  and  $I_2$  flowing in the two resistors. Then there is no need to calculate the current  $I_3$  as its just the sum of  $I_1$  and  $I_2$ . So Kirchoff's second voltage law simply becomes:

- Equation No 1 :  $10 = 50I_1 + 40I_2$
- Equation No 2 :  $20 = 40I_1 + 60I_2$

therefore, one line of math's calculation have been saved.

### 1.6.1 Mesh Current Analysis

A more easier method of solving the above circuit is by using **Mesh Current Analysis** or **Loop Analysis** which is also sometimes called **Maxwell's Circulating Currents** method. Instead of labelling the branch currents we need to label each "closed loop" with a circulating current. As a general rule of thumb, only label inside loops in a clockwise direction with circulating currents as the aim is to cover all the elements of the circuit at least once. Any required branch current may be found from the appropriate loop or mesh currents as before using Kirchoff's method.

For example:  $i_1 = I_1$  ,  $i_2 = -I_2$  and  $i_3 = I_1 - I_2$

We now write Kirchoff's voltage law equation in the same way as before to solve them but the advantage of this method is that it ensures that the information obtained from the circuit equations is the minimum required to solve the circuit as the information is more general and can easily be put into a matrix form.

For example, consider the circuit from the previous example.

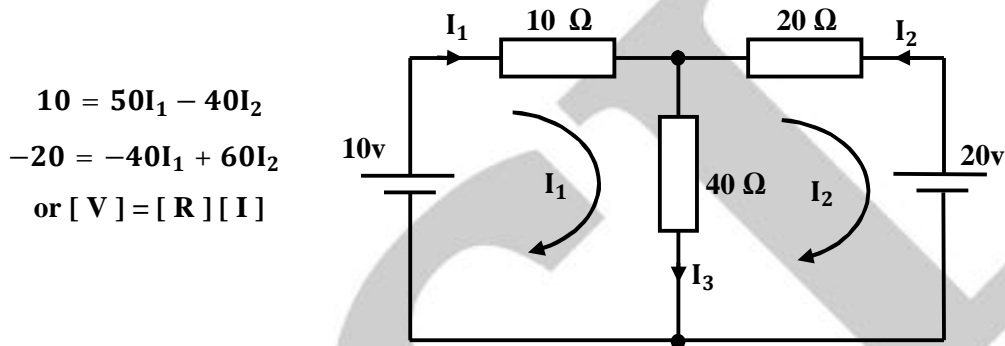


Fig. 1.9

These equations can be solved quite quickly by using a single mesh impedance matrix  $Z$ . Each element ON the principal diagonal will be "positive" and is the total impedance of each mesh. Where as, each element OFF the principal diagonal will either be "zero" or "negative" and represents the circuit element connecting all the appropriate meshes. This then gives us a matrix of:

$$[V] = [R] \cdot [I]$$

$$\begin{bmatrix} 10 \\ -20 \end{bmatrix} = \begin{bmatrix} 10 + 40 & -40 \\ -40 & 60 \end{bmatrix} \cdot \begin{bmatrix} I_1 \\ I_2 \end{bmatrix}$$

Where:

- $[V]$  gives the total battery voltage for loop 1 and then loop 2.
- $[I]$  states the names of the loop currents which we are trying to find.
- $[R]$  is called the resistance matrix.

and this gives  $I_1$  as  $-0.143$  Amps and  $I_2$  as  $-0.429$  Amps

$$\text{As: } I_3 = I_1 - I_2$$

The current  $I_3$  is therefore given as:  $-0.143 - (-0.429) = 0.286$  Amps

which is the same value of  $0.286$  amps, we found using Kirchoff's circuit law in the previous tutorial.

### 1.6.2 Mesh Current Analysis Summary

This "look-see" method of circuit analysis is probably the best of all the circuit analysis methods with the basic procedure for solving **Mesh Current Analysis** equations is as follows:

- Label all the internal loops with circulating currents. ( $I_1, I_2, \dots, I_L$  etc)
- Write the [  $L \times 1$  ] column matrix [  $V$  ] giving the sum of all voltage sources in each loop.
- Write the [  $L \times L$  ] matrix, [  $R$  ] for all the resistances in the circuit as follows;
  - $R_{11}$  = the total resistance in the first loop.
  - $R_{nn}$  = the total resistance in the Nth loop.
  - $R_{JK}$  = the resistance which directly joins loop J to Loop K.
- Write the matrix or vector equation [  $V$  ] = [  $R$  ] x [  $I$  ] where [  $I$  ] is the list of currents to be found.

### 1.6.3 Nodal Voltage Analysis

**Nodal Voltage Analysis** uses the "Nodal" equations of Kirchoff's first law to find the voltage potentials around the circuit. If there are "N" nodes in the circuit there will be "N-1" independent nodal equations and these alone are sufficient to describe and hence solve the circuit.

At each node point write down Kirchoff's first law equation, that is: "*the currents entering a node are exactly equal in value to the currents leaving the node*" then express each current in terms of the voltage across the branch. For "N" nodes, one node will be used as the reference node and all the other voltages will be referenced or measured with respect to this common node.

For example, consider the circuit from the example section.

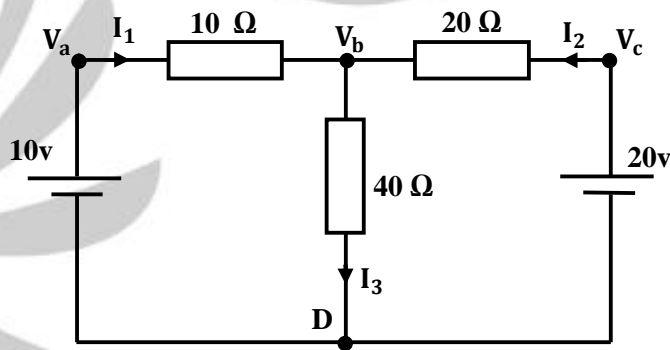


Fig. 1.10

In the above circuit, node D is chosen as the reference node and the other three nodes are assumed to have voltages,  $V_a$ ,  $V_b$  and  $V_c$  with respect to node D. For example;

$$\frac{(V_a - V_b)}{10} + \frac{(V_c - V_b)}{20} = \frac{V_b}{40}$$

As  $V_a = 10v$  and  $V_c = 20v$ ,  $V_b$  can be easily found by:

$$1 + \frac{V_b}{10} + 1 - \frac{V_b}{20} = \frac{V_b}{40}$$

$$2 = V_b \left( \frac{1}{40} + \frac{1}{20} + \frac{1}{10} \right)$$

$$V_b = \frac{80}{7} V$$

$$\therefore I_3 = \frac{2}{7} \text{ or } 0.286 \text{ Amps}$$

From both Mesh and Nodal Analysis methods we have looked at so far, this is the simplest method of solving this particular circuit. Generally, nodal voltage analysis is more appropriate when there are a larger number of current sources around. The network is then defined as:  $[ I ] = [ Y ] [ V ]$  where  $[ I ]$  are the driving current sources,  $[ V ]$  are the nodal voltages to be found and  $[ Y ]$  is the admittance matrix of the network which operates on  $[ V ]$  to give  $[ I ]$ .

#### 1.6.4 Nodal Voltage Analysis Summary

The basic procedure for solving **Nodal** Analysis equations is as follows:

- Write down the current vectors, assuming currents into a node are positive. ie, a  $(N \times 1)$  matrices for "N" independent nodes.
- Write the admittance matrix  $[Y]$  of the network where:
  - $Y_{11}$  = the total admittance of the first node.
  - $Y_{22}$  = the total admittance of the second node.
  - $R_{JK}$  = the total admittance joining node J to node K.
- For a network with "N" independent nodes,  $[Y]$  will be an  $(N \times N)$  matrix and that  $Y_{nn}$  will be positive and  $Y_{jk}$  will be negative or zero value.
- The voltage vector will be  $(N \times L)$  and will list the "N" voltages to be found.

## 1.7. Voltage/Current Source

### 1.7.1. Ideal vs. Practical voltage source

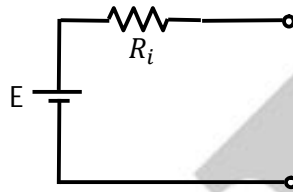


Fig 1.11 Practical Voltage Source

Figure above depicts the symbol of a practical voltage source. Here  $E$  is the EMF of source and  $R_i$  is the internal resistance of the source. For an ideal source,  $R_i$  is zero and for a practical source,  $R_i$  is finite & small.

### 1.7.2. Ideal vs. Practical current source

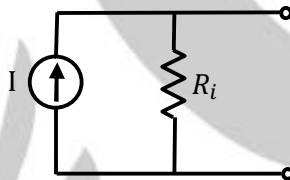


Fig 1.12. Practical Current Source

Figure above depicts the symbol of a practical current source. Here,  $I$  is the current of source and  $R_i$  is internal resistance of source. For an ideal current source,  $R_i$  is infinite and for a practical source,  $R_i$  is finite and large.

### 1.7.3. Dependent Sources

A source is called dependent if voltage / current of the source depends on voltage / current in some other part of the network. Depending upon the nature of the source, dependent sources can be classified as below.

#### 1.7.3.1 Voltage Controlled Voltage Source (VCVS )

Here the voltage of the voltage source depends on voltage across some other element in the network.

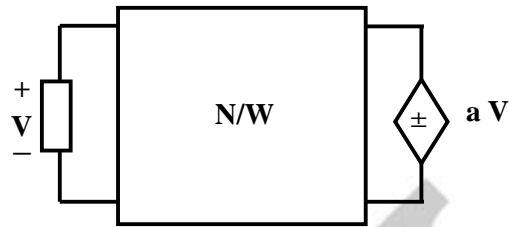


Fig 1.13.VCVS

### 1.7.3.2 Voltage Controlled Current Source (VCCS)

For a VCCS, the current of the current source depends on voltage across some other element the network.

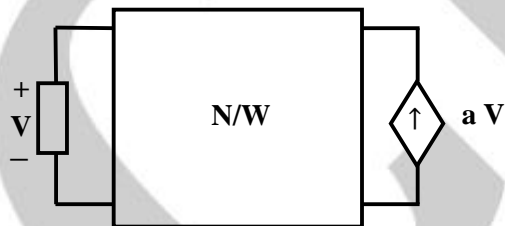


Fig 1.14.VCCS

### 1.7.3.3 Current Controlled Voltage Source (CCVS)

For a CCVS, the voltage of the voltage source depends on current through some other element in the network.

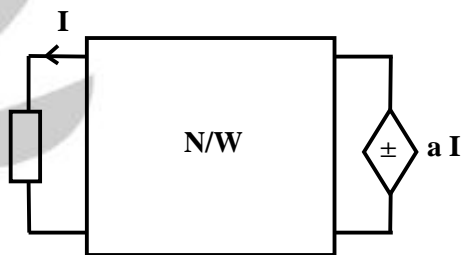


Fig 1.15.CCVS

### 1.7.3.4 Current Controlled Current Source (CCCS)

For a CCCS, the current of the current sources depends on current through some other element in the network.

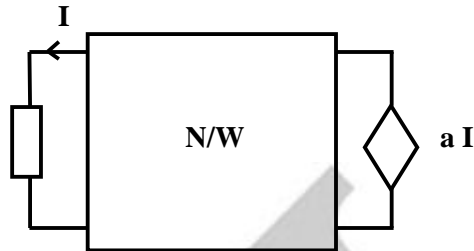


Fig 1.16.CCCS

### 1.8. Power and Energy:

The instantaneous power  $p(t)$  delivered to a passive element is given by

$$p(t) = v(t) i(t) \text{ Watts}$$

Energy (joules) delivered upto time  $t$  is given by

$$E(t) =$$

Where  $v(t)$  and  $i(t)$  are instantaneous voltage across and current through passive element.

### 1.9. Superposition theorem

In a linear bilateral network, the current through or voltage across any element is equal to algebraic sum of currents through (or voltages across) the elements when each of the independent sources are acting alone, provided each of the independent sources are replaced by corresponding internal resistances. Let's look at our example circuit show below and apply Superposition Theorem to it:

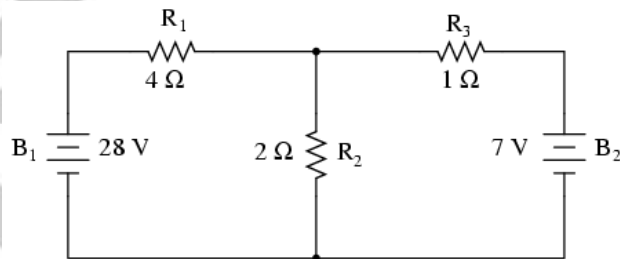


Fig. 1.17 Superposition Theorem

Since we have two sources of power in this circuit, we will have to calculate two sets of values for voltage drops and/or currents, one for the circuit with only the 28 volt battery in effect

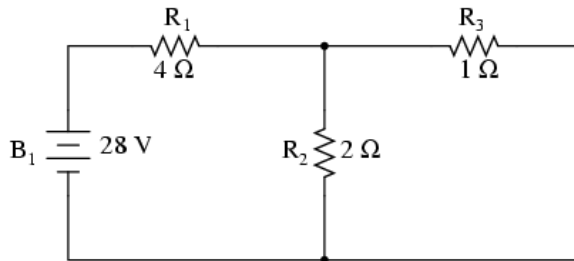


Fig. 1.18

and one for the circuit with only the 7 volt battery in effect:

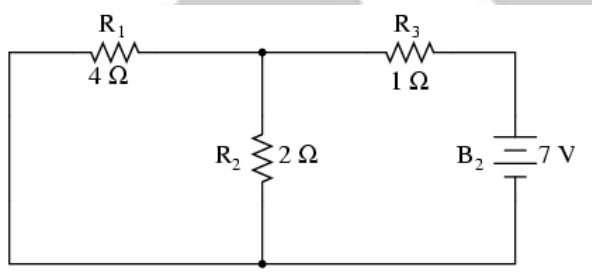


Fig. 1.19

When re-drawing the circuit for series/parallel analysis with one source, all other voltage sources are replaced by shorts and all current sources with open circuits. Since we only have voltage sources (batteries) in our example circuit, we will replace every inactive source during analysis with a wire.

Analyzing the circuit with only the 28 volt battery, we obtain the following values for voltage and current:

	$R_1$	$R_2$	$R_3$	$R_2 // R_3$	$R_1 + R_2 // R_3$ Total	
E	24	4	4	4	28	Volts
I	6	2	4	6	6	Amps
R	4	2	1	0.667	4.667	Ohms

Table 1.2

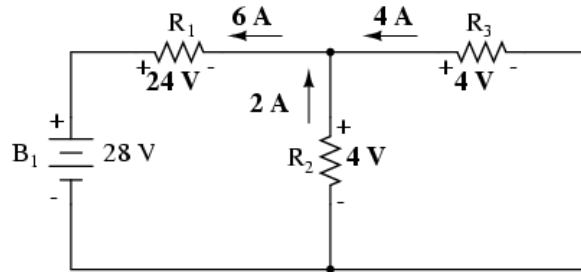


Fig. 1.20

Analyzing the circuit with only the 7 volt battery, we obtain another set of values for voltage and current:

	$R_1$	$R_2$	$R_3$	$R_1 // R_2$	$R_3 + R_1 // R_2$ Total	
E	4	4	3	4	7	Volts
I	1	2	3	3	3	Amps
R	4	2	1	1.333	2.333	Ohms

Table 1.3

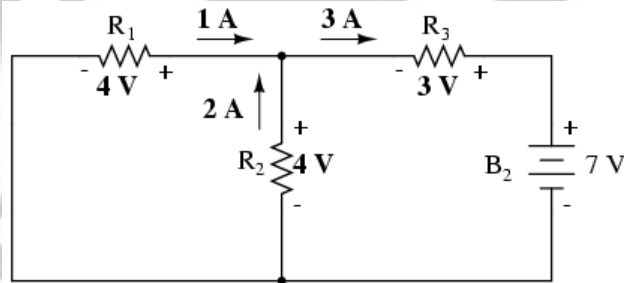


Fig. 1.21

When superimposing these values of voltage and current, we have to be very careful to consider polarity (voltage drop) and direction (electron flow), as the values have to be added *algebraically*.





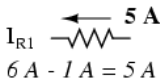
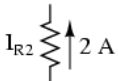
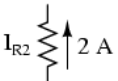
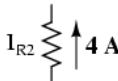


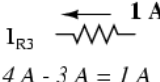
With 28 V battery	With 7 V battery	With both batteries
 $I_{R1}$	 $I_{R1}$	 $I_{R1}$ $6 A - 1 A = 5 A$
 $I_{R2}$	 $I_{R2}$	 $I_{R2}$ $2 A + 2 A = 4 A$
 $I_{R3}$	 $I_{R3}$	 $I_{R3}$ $4 A - 3 A = 1 A$

Table 1.5

Once again applying these superimposed figures to our circuit:

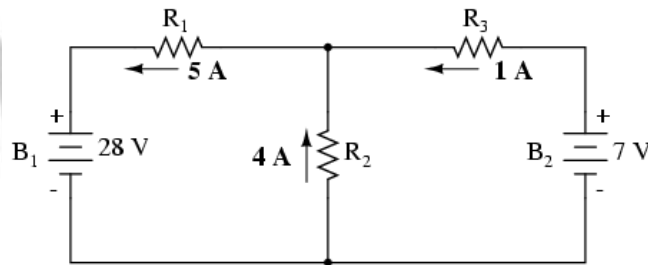


Fig. 1.23

Superposition theorem is only applicable to linear and bilateral circuits. Hence the same cannot be applied to circuits which contain diodes / transistors. Also internal resistance for a voltage source is zero and for current source, the same is infinite. Hence the voltage source should be replaced by short. Similarly, the current source should be replaced by open.

### 1.10. Source conversion theorem

Source conversion theorem states that a voltage source,  $E$  in series with resistance, as seen from terminals a and b is equivalent to a current source,  $I = E/R$  in parallel with resistance,  $R$ .

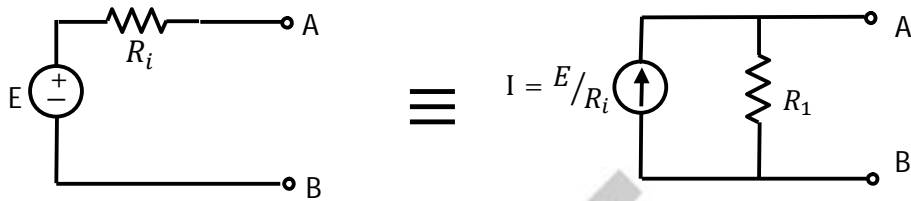


Fig. 1.24 Source conversion theorem

### 1.11. Thevenin’s and Norton’s Theorems

#### 1.11.1. Thevenin’s Theorem

**Thevenin’s Theorem** states that "Any linear circuit containing several voltages and resistances can be replaced by just a Single Voltage in series with a Single Resistor". In other words, it is possible to simplify any "Linear" circuit, no matter how complex, to an equivalent circuit with just a single voltage source in series with a resistance connected to a load as shown below. **Thevenin’s Theorem** is especially useful in analyzing power or battery systems and other interconnected circuits where it will have an effect on the adjoining part of the circuit.

#### Thevenin’s Equivalent Circuit:-

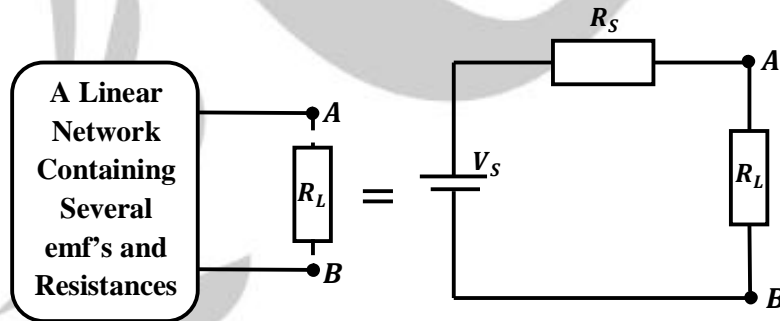


Fig. 1.25 Thevenin’s Theorem Illustration

As far as the load resistor  $R_L$  is concerned, any "one-port" network consisting of resistive circuit elements and energy sources can be replaced by one single equivalent resistance  $R_s$  and equivalent voltage  $V_s$ , where  $R_s$  is the source resistance value looking back into the circuit and  $V_s$  is the open circuit voltage at the terminals.

For example, consider the circuit shown below:

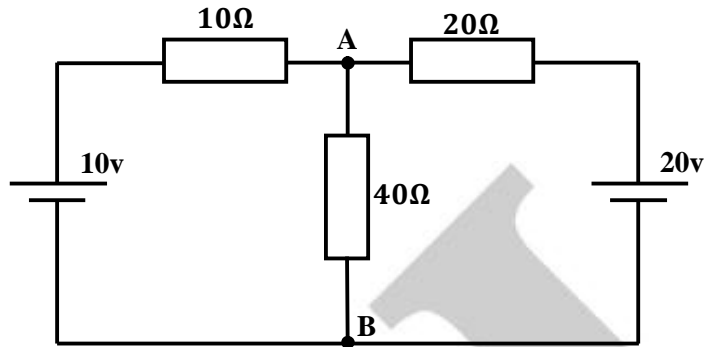


Fig. 1.26

Firstly, we have to remove the centre  $40\Omega$  resistor and short out (not physically as this would be dangerous) all the emf's connected to the circuit, or open circuit any current sources. The value of resistor  $R_s$  is found by calculating the total resistance at the terminals A and B with all the emf's removed, and the value of the voltage required  $V_s$  is the total voltage across terminals A and B with an open circuit and no load resistor  $R_s$  connected. Then, we get the following circuit.

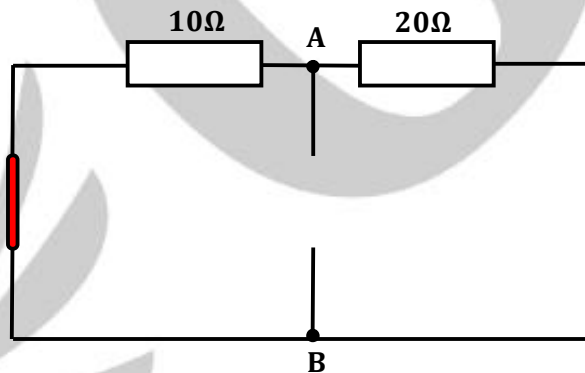


Fig. 1.27

### Equivalent Resistance ( $R_s$ )

$10\Omega$  Resistor in Parallel with the  $20\Omega$  Resistor

$$R_T = \frac{R_1 \times R_2}{R_1 + R_2} = \frac{20 \times 10}{20 + 10} = 6.67\Omega$$

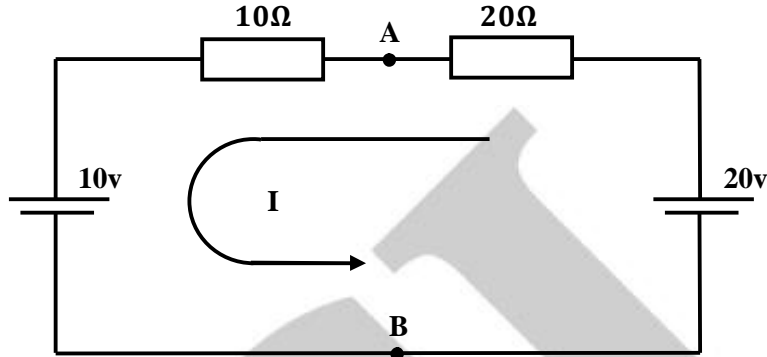
Equivalent Voltage ( $V_s$ )

Fig. 1.28

We now need to reconnect the two voltages back into the circuit, and as  $V_s = V_{AB}$  the current flowing around the loop is calculated as:

$$I = \frac{20v - 10v}{20\Omega + 10\Omega} = 0.33 \text{ amps}$$

so the voltage drop across the 20Ω resistor can be calculated as:

$$V_{AB} = 20 - (20\Omega \times 0.33\text{amps}) = 13.33 \text{ volts.}$$

Then the Thevenin's Equivalent circuit is shown below with the 40Ω resistor connected.

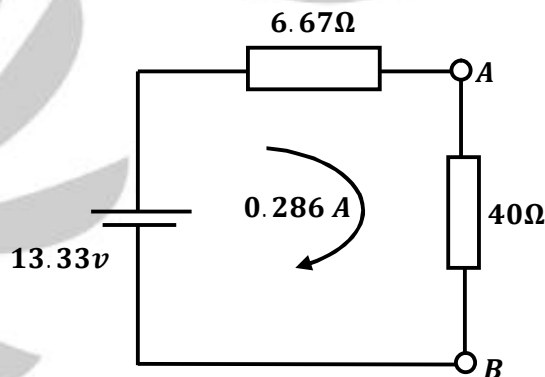


Fig. 1.29

and from this the current flowing in the circuit is given as:

$$I = \frac{13.33v}{6.67\Omega + 40\Omega} = 0.286 \text{ amps}$$

**Thevenin's theorem** can be used as a circuit analysis method and is particularly useful if the load is to take a series of different values. It is not as powerful as *Mesh* or *Nodal* analysis in larger networks because the use of Mesh or Nodal analysis is usually necessary in any Thevenin exercise, so it might as well be used from the start. However, Thevenin's equivalent circuits of **Transistors, Voltage Sources** such as batteries etc, are very useful in circuit design.

## Thevenin's Theorem Summary

The basic procedure for solving a circuit using **Thevenin's Theorem** is as follows:

- Remove the load resistor  $R_L$  or component concerned.
- Find  $R_S$  by shorting all voltage sources or by open circuiting all the current sources.
- Find  $V_S$  by the usual circuit analysis methods.
- Find the current flowing through the load resistor  $R_L$ .

### 1.11.2. Norton's Theorem

**Norton's Theorem** states that "Any linear circuit containing several energy sources and resistances can be replaced by a single Constant Current generator in parallel with a Single Resistor". As far as the load resistance,  $R_L$  is concerned this single resistance,  $R_S$  is the value of the resistance looking back into the network with all the current sources open circuited and  $I_S$  is the short circuit current at the output terminals as shown below.

### Norton's equivalent circuit

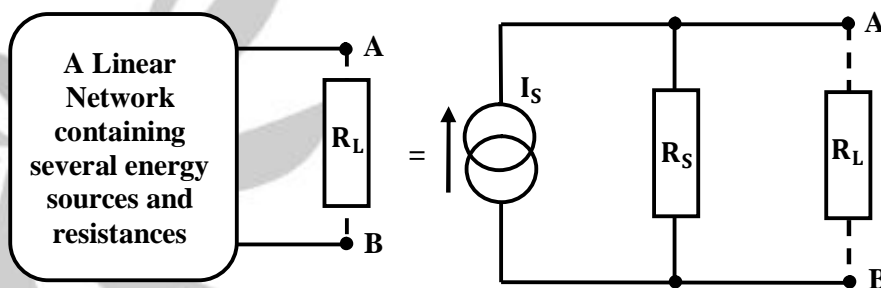


Fig. 1.30 Norton's Theorem Illustration

The value of this "constant current" is one which would flow if the two output terminals were shorted together while the source resistance would be measured looking back into the terminals, (the same as Thevenin).

For example, consider the circuit shown below:

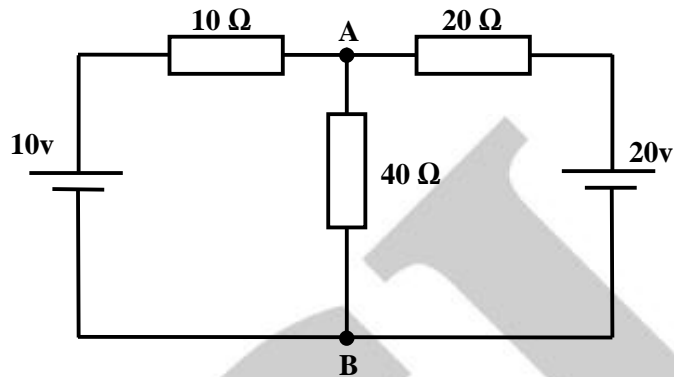


Fig. 1.31

To find the Norton's equivalent of the above circuit we firstly have to remove the centre  $40\Omega$  load resistor and short out the terminals A and B to give us the following circuit.

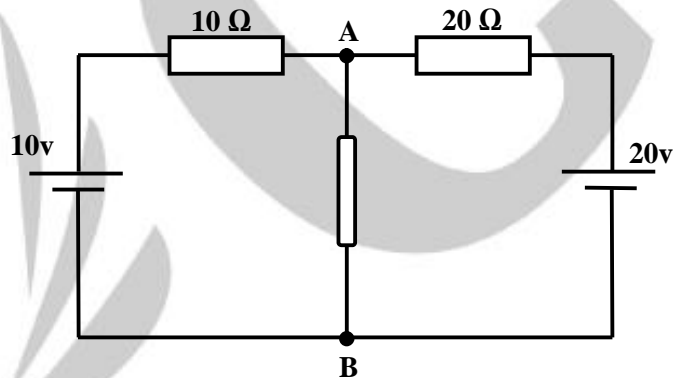


Fig. 1.32

When the terminals A and B are shorted together the two resistors are connected in parallel across their two respective voltage sources and the currents flowing through each resistor as well as the total short circuit current can now be calculated as:

$$I_1 = \frac{10v}{10\Omega} = 1 \text{ amp}, \quad I_2 = \frac{20v}{20\Omega} = 1 \text{ amp}$$

therefore,  $I_{\text{short-circuit}} = I_1 + I_2 = 2 \text{ amps}$

If we short-out the two voltage sources and open circuit terminals A and B, the two resistors are now effectively connected together in parallel. The value of the internal resistor  $R_s$  is found by calculating the total resistance at the terminals A and B giving us the following circuit.

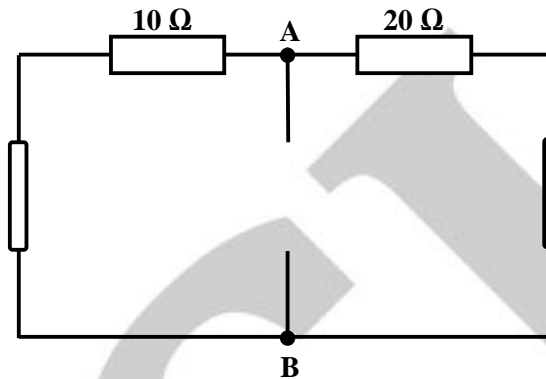


Fig. 1.33

### Equivalent Resistance ( $R_s$ )

10Ω Resistor in Parallel with the 20Ω Resistor

$$R_T = \frac{R_1 \times R_2}{R_1 + R_2} = \frac{20 \times 10}{20 + 10} = 6.67 \Omega$$

Having found both the short circuit current,  $I_s$  and equivalent internal resistance,  $R_s$  this then gives us the following Norton's equivalent circuit.

### Norton's equivalent circuit

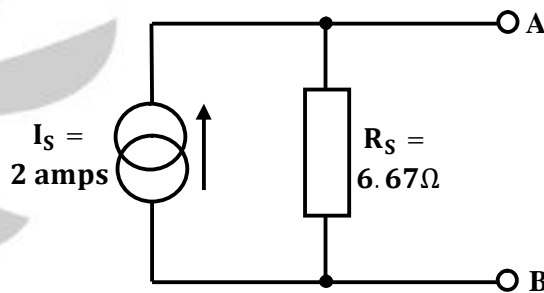


Fig. 1.34

Ok, so far so good, but we now have to solve with the original 40Ω load resistor connected across terminals A and B as shown below.

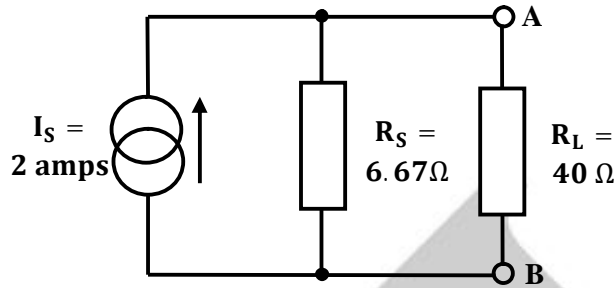


Fig. 1.35

Again, the two resistors are connected in parallel across the terminals A and B which gives us a total resistance of:

$$R_T = \frac{R_1 \times R_2}{R_1 + R_2} = \frac{6.67 \times 40}{6.67 + 40} = 5.72 \Omega$$

The voltage across the terminals A and B with the load resistor connected is given as:

$$V_{A-B} = I \times R = 2 \times 5.72 = 11.44\text{v}$$

Then the current flowing in the  $40\Omega$  load resistor can be found as:

$$I = \frac{V}{R} = \frac{11.44}{40} = 0.286 \text{ amps}$$

## Norton's Theorem Summary

The basic procedure for solving a circuit using **Norton's Theorem** is as follows:

- Remove the load resistor  $R_L$  or component concerned.
- Find  $R_S$  by shorting all voltage sources or by open circuiting all the current sources.
- Find  $I_S$  by placing a shorting link on the output terminals A and B.
- Find the current flowing through the load resistor  $R_L$ .

## 1.12. Maximum power transfer theorem (as applied to dc network)

Maximum power transfer theorem in a dc network states a condition on load resistance for which the maximum power is transferred to the load resistance. In a dc network, maximum power transferred to the load when the load resistance is equal to Thevenin's ( / Norton's) resistance as viewed from load terminals.

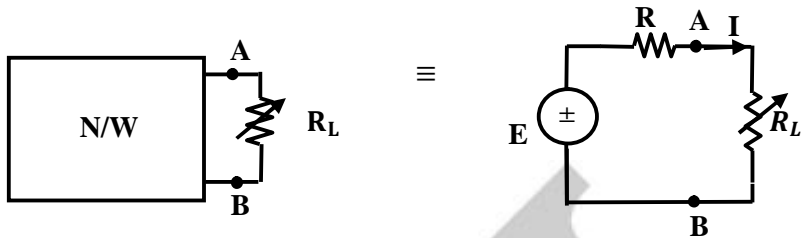


Fig. 1.36 Demonstration of maximum power transfer theorem

For maximum power transfer,  $R_L = R$

Also,  $P_{max} = \frac{E^2}{4R}$  and corresponding current is  $I = \frac{E}{2R}$

Total power consumed in the circuit =  $\frac{E^2}{4R} + \frac{E^2}{4R} = \frac{E^2}{2R}$

### 1.13. Star-Delta transformation

To convert a delta network to an equivalent star network we need to derive a transformation formula for equating the various resistors to each other between the various terminals. Consider the circuit below.

#### Delta to Star Network

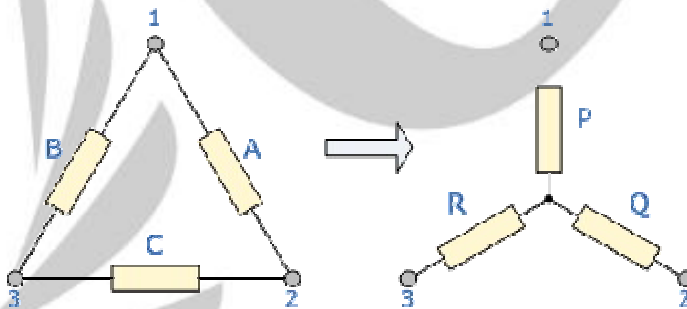


Fig. 1.37 Star-Delta Conversion

#### Delta to Star Transformations Equations

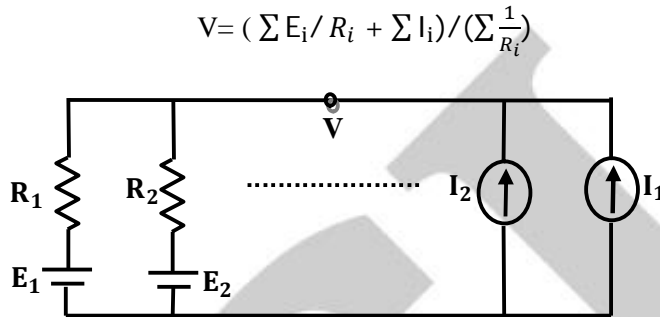
$$P = \frac{AB}{A + B + C} \quad Q = \frac{AC}{A + B + C} \quad R = \frac{BC}{A + B + C}$$

#### Star Delta Transformation Equations

$$A = \frac{PQ}{R} + Q + P \quad B = \frac{RP}{Q} + P + R \quad C = \frac{QR}{P} + Q + R$$

**1.14. Mcmillan’s Theorem**

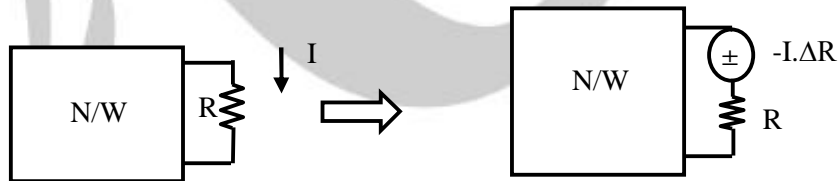
Mcmillan’s theorem can be applied to the circuits of the form shown and is based on nodal analysis.



**Fig. 1.38 Mcmillan’s Theorem**

**1.15. Substitution theorem**

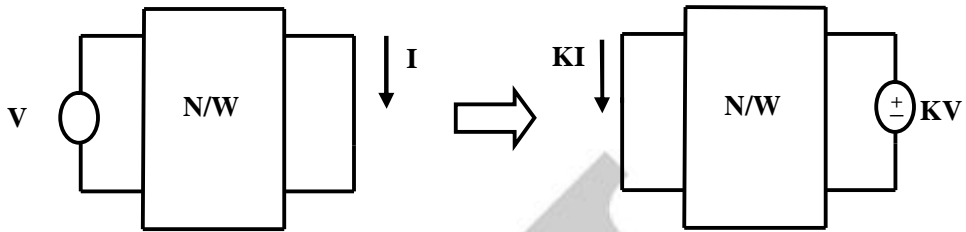
Substitution theorem can be used to get incremental change in voltage/current for any circuit element when a resistance R is changed by ΔR and the same can be found by inserting a voltage source – I. ΔR in series with R. Here I is the current through resistance R.



**Fig. 1.39 Demonstration of substitution theorem**

**1.16. Reciprocity theorem**

Reciprocity theorem states that in a linear bilateral network, voltage source and current sink can be interchanged.



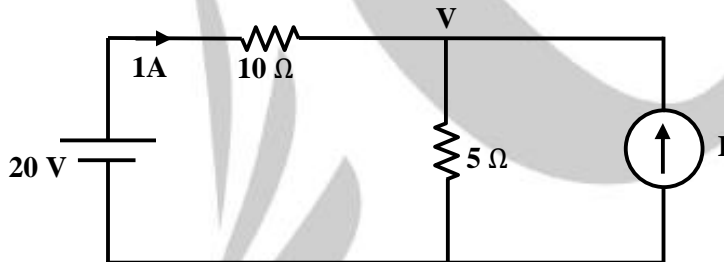
**Fig. 1.40 Demonstration of reciprocity theorem**

Following are the conditions to be satisfied to apply reciprocity theorem:

- Only one source is present
- No dependent sources is present
- No initial conditions (  $\Rightarrow$  zero state )

Circuit which satisfies above conditions is called “Reciprocity network”

**Example:** In the circuit shown below, find I if the current through  $10\ \Omega$  resistor is 1 A



**Fig. 1.41**

- (A) 1 A
- (B) - 0.5 A
- (C) 0.25 A
- (D) None of these

**Solution:**

[Ans. A]

$$\frac{V-20}{10} + \frac{V}{5} - I = 0 \text{ and } \frac{(20-V)}{10} = 1$$

$$\therefore V = 10V \text{ and } I = 1A$$

**Example:** In the network shown below, find current through resistance R .

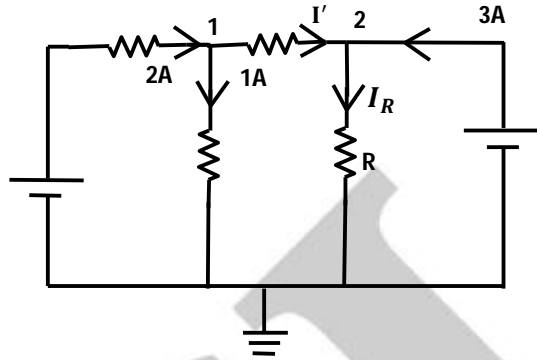


Fig. 1.42

**Solution:**

Apply Kirchoff's current law at node 1,  $-2 + 1 + I' = 0 \Rightarrow I' = 1A$   
 Apply Kirchoff's current law at node 2,  $I' - I_R + 3 = 0 \Rightarrow I_R = 4A$

**Example:** For the network shown below, find the Thevenin equivalent circuit as seen from terminals A and B.

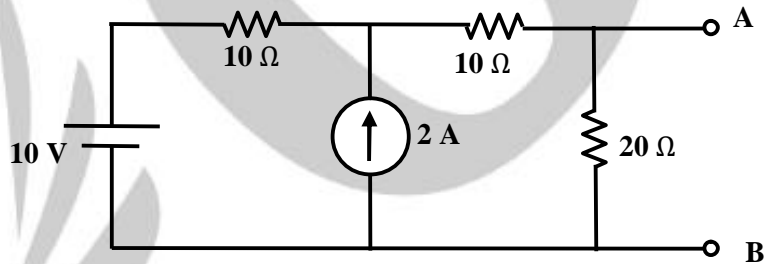
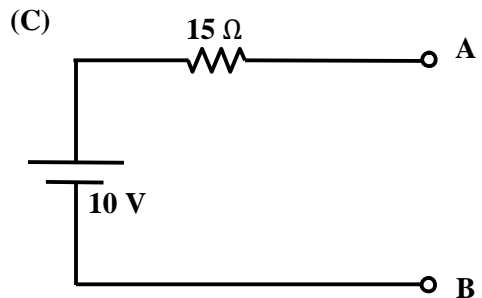
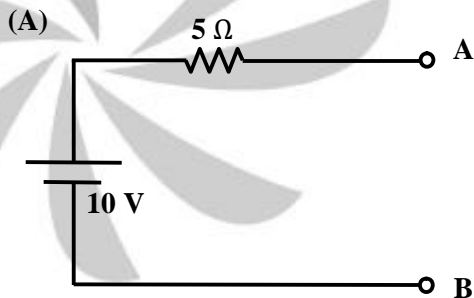
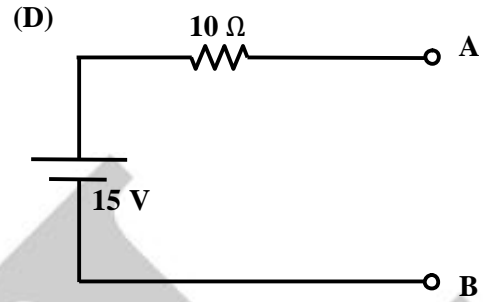
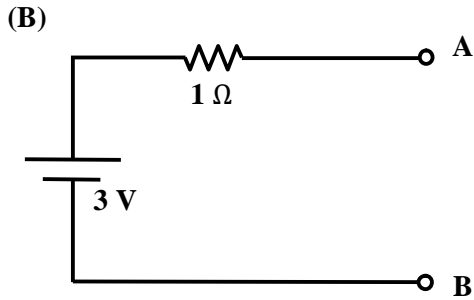


Fig. 1.43





**Solution:**

[Ans. D]

$$V_{th} = V_{OC} = 5 + 10 = 15 \text{ V}$$

$$R_{th} = 10 \Omega$$

**Example:** In the network shown below, find the voltage across resistance R.

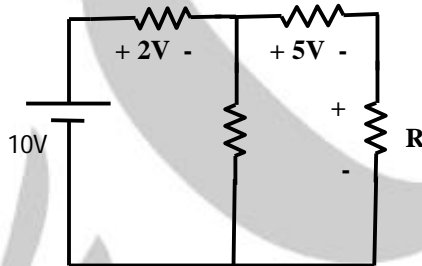


Fig. 1.44

**Solution:**

Apply Kirchoff's voltage law to the outer closed path,  $2+5+V_R=10 \Rightarrow V_R = 3\text{V}$

**Example:** The circuit shown below as seen from terminals a and b, is equivalent to \_\_\_\_\_

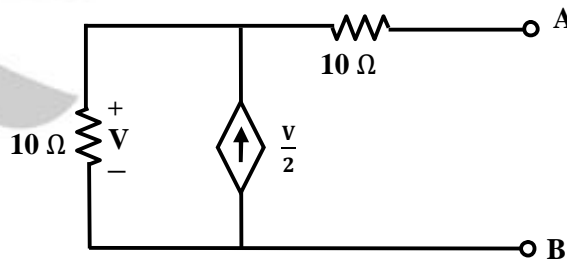


Fig. 1.45

- (A) 2.5  $\Omega$  resistor  
 (B) 7.5  $\Omega$  resistor

- (C) 5  $\Omega$  resistor  
 (D) 10  $\Omega$  resistor

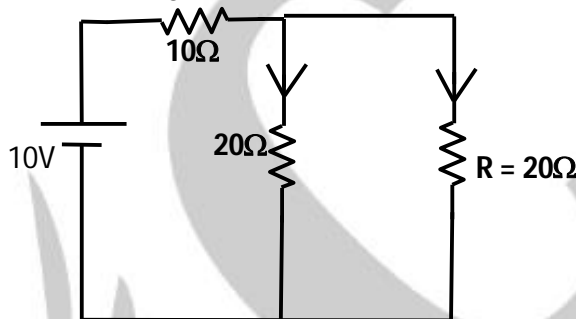
**Solution:****[Ans. B]**

Assume 1A current source between terminals a and b,

$$\frac{V}{10} - \frac{V}{2} - 1 = 0 \Rightarrow V = -2.5 \text{ V}$$

$$V_{AB} = 10 + V = 7.5 \text{ V}$$

$$R_N = V_{AB}/1 = 7.5 \Omega$$

**Example:** Find the current through resistance R in the circuit below.**Fig. 1.46****Solution:**Resistance as seen from 10 V source =  $10 + (20//20) = 20\Omega$ .Current delivered by 10 V source =  $10/20 = 0.5 \text{ A}$ 

$$I_R = 0.5 \times \frac{20}{(20+20)} = 0.25 \text{ A (by current division)}$$

**Example:** In the circuit shown below, find the value of  $R_L$  for which maximum power is dissipated in  $R_L$ .

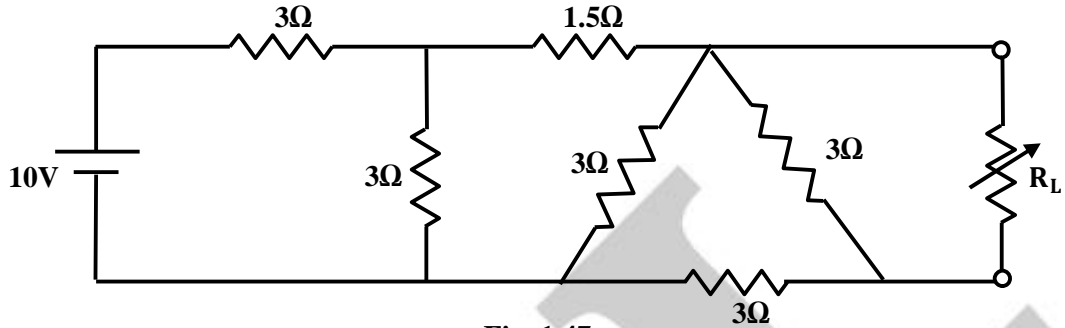


Fig. 1.47

- (A) 2.23 Ω
- (B) 3 Ω
- (C) 1.5 Ω
- (D) 1.8 Ω

**Solution:**

[Ans. D]

For maximum power dissipation,  $R_L = R_{th} = 1.8 \Omega$  (use Y – Δ conversion)

**Example:** Find the current I in the following circuit:

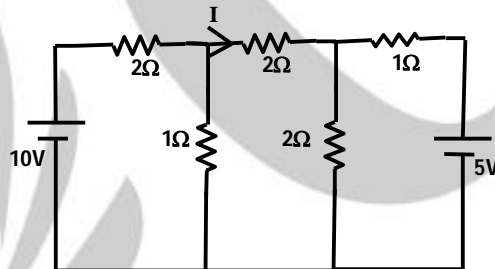


Fig. 1.48

**Solution:**

Assume mesh currents as  $I_1, I_2,$  &  $I_3$ .

By Applying mesh analysis,

$$\begin{aligned}
 2I_1 + 1(I_1 - I_2) &= 10 && \text{P } 3I_1 - I_2 = 10 \\
 2I_2 + 2(I_2 - I_3) + 1(I_2 - I_1) &= 0 && \text{P } -I_1 + 5I_2 - 2I_3 = 0 \\
 1I_3 + 2(I_3 - I_2) &= -5 && \text{P } -2I_2 + 3I_3 = -5
 \end{aligned}$$

By Cramer's rule,  $I_2 = \frac{\begin{vmatrix} 3 & 10 & 0 \\ -1 & 0 & -2 \\ 0 & -5 & 3 \end{vmatrix}}{\begin{vmatrix} 3 & -1 & 0 \\ -1 & 5 & -2 \\ 0 & -2 & 3 \end{vmatrix}} = \frac{3(0-10)-10(-3)}{3(15-4)+1(-3)} = 0 \Rightarrow I=I_2 = 0A$

**Example:** Find current I through 5Ω resistor in the following circuit:

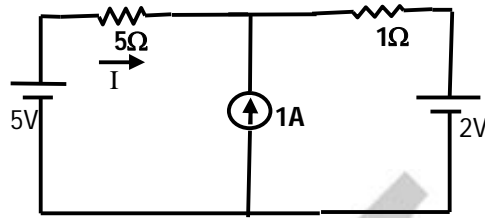


Fig. 1.49

**Solution:**

Assume mesh currents  $I_1$  &  $I_2$  (super mesh),

$$\therefore 5I_1 + 1 \cdot I_2 = 5 - 2 \Rightarrow 5I_1 + I_2 = 3$$

$$I_2 - I_1 = 1 \Rightarrow I_1 - I_2 = -1$$

$$\therefore 6I_1 = 2 \Rightarrow I_1 = 1/3A$$

$$I_2 = -2/3A$$

$$I = I_1 = 1/3A$$

**Example:** Find voltage of node 1 with respect to ground

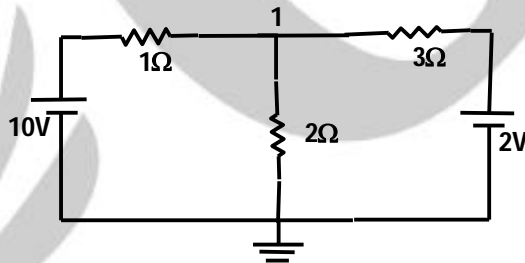


Fig. 1.50

**Solution:**

By Applying nodal analysis at node 1,  $\frac{V-10}{1} + \frac{V}{2} + \frac{V-2}{3} = 0$

$$6V - 60 + 3V + 2V - 4 = 0 \Rightarrow 11V = 64 \Rightarrow V = 64/11 \text{ V}$$

**Example:** Find E in the following circuit if  $V_1 = 1.5V$ .

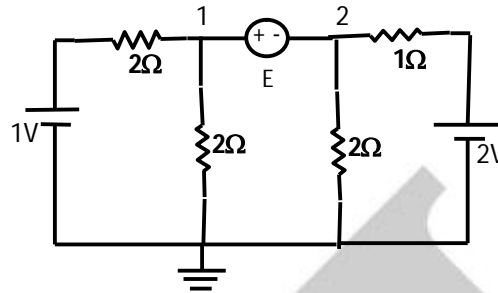


Fig. 1.51

**Solution:**

By Applying nodal analysis, at super node,  $\frac{V_1-1}{2} + \frac{V_1}{2} + \frac{V_2}{2} + \frac{V_2-2}{1} = 0 \Rightarrow V_2 = \frac{2}{3}V$

$$V_1 - V_2 = E \Rightarrow$$

$$E = 3/2 - 2/3 = \frac{9-4}{6} = 5/6V$$

**Example:** Find voltage across 2Ω resistor using superposition theorem.

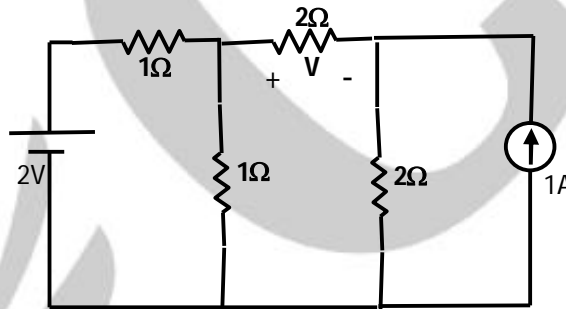


Fig. 1.52

**Solution:**

When 2V source is acting alone,

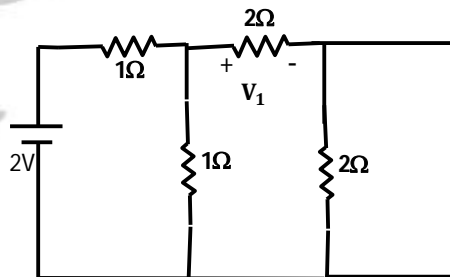


Fig. 1.53

$$V_1 = \frac{2}{\left(1 - \frac{4}{5}\right)} \times \frac{4}{5} \times \frac{2}{4} = \frac{2}{9} \times 5 \times \frac{1}{5} \times 2 = \frac{4}{9} V$$

When 1A source is acting alone

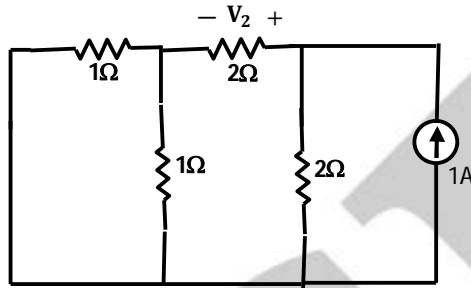


Fig. 1.54

$$V_2 = 1 \times \frac{2}{(2+2.5)} \times 2 = \frac{4}{4.5} = \frac{8}{9} V$$

By superposition theorem,  $V = V_1 - V_2 = \frac{4}{9} - \frac{8}{9} = \frac{-4}{9} V$

**Example:** Find Thevenin's and Norton's equivalent as viewed from terminals A & B.

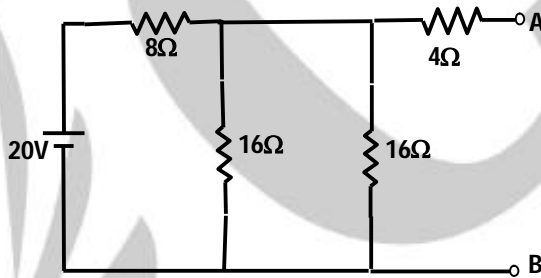


Fig. 1.55

**Solution:**

For Thevenin's equivalent network,

$$V_{OC} = 20 \times \frac{8}{16} = 10V$$

$$R_{th} = \frac{8 \times 8}{16} + 4 = 8W$$

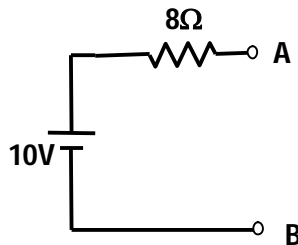


Fig. 1.56

For Norton's equivalent network,

$$I_{sh} = \frac{20}{\left(\frac{32}{12} + 8\right)} \times \frac{8}{12} = \frac{20 \times 12}{128} \times \frac{8}{12} = \frac{5}{4} A$$

$$R_N = \frac{8 \times 8}{16} + 4 = 8 \Omega$$

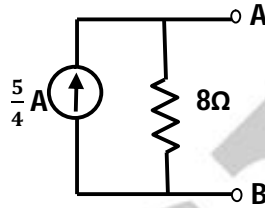


Fig. 1.57

From above we see that Norton's equivalent network can be obtained by performing source conversion on Thevenin's equivalent network and vice versa.

**Example:** Find the voltage across 5Ω resistor (between terminals A & B).

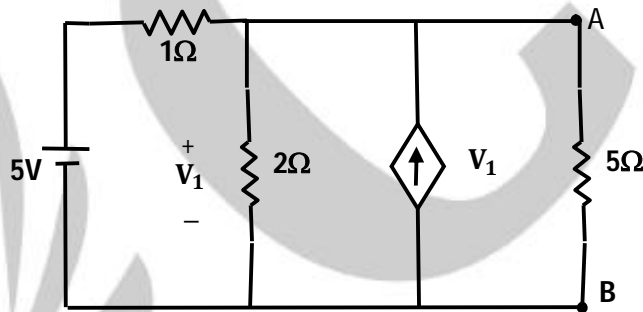


Fig. 1.58

**Solution:**

Find Thevenin's equivalent network as viewed from the terminals A & B,

To find  $V_{OC}$ ,

$$\frac{V_1 - 5}{1} + \frac{V_1}{2} - V_1 = 0$$

$$\Rightarrow 2V_1 - 10 + V_1 - 2V_1 = 0$$

$$\Rightarrow V_1 = 10V$$

To find  $I_{sh}$ ,

$$V_1 = 0 \Rightarrow I_{sh} = 5A$$

$$R_{th} = \frac{V_{OC}}{I_{sh}} = \frac{10}{5} = 2 \Omega$$

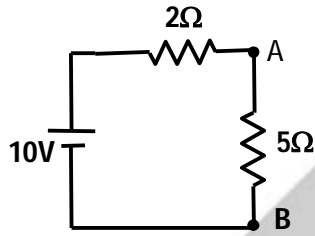


Fig. 1.59

$$V_{AB} = \frac{10 \times 5}{7} = \frac{50}{7} \text{ V}$$

**Example:** Find Thevenin's equivalent circuit as viewed from terminals A and B for the following circuit

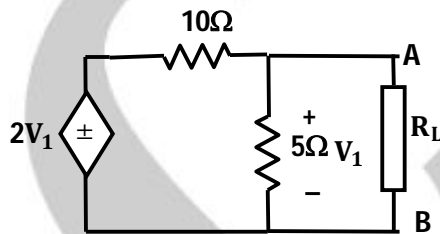


Fig. 1.60

**Solution:**

Circuit contains dependent sources only.  $\therefore V_{th} = 0$

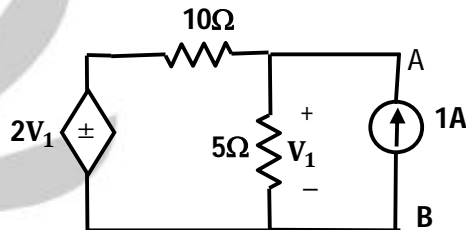


Fig. 1.61

$$\frac{V_1 - 2V_1}{10} + \frac{V_1}{5} - 1 = 0 \Rightarrow V_1 = 10\text{V}$$

$$R_{th} = \frac{V_1}{1} = \frac{10}{1} = 10\Omega$$

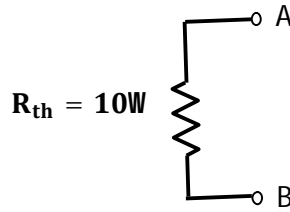


Fig. 1.62

**Example:** Consider the electrical network given below. If  $R_{eq}$  is a resistance as seen from terminals A and B, find  $R_{eq}$

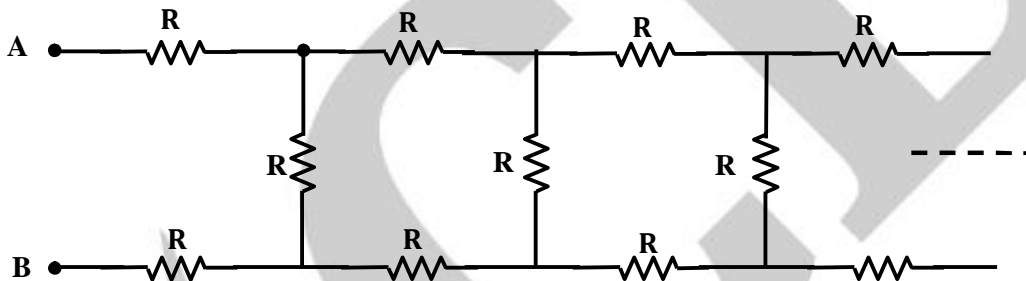


Fig. 1.63

- (A)  $3R$
- (B)  $(1 + \sqrt{2})R$
- (C)  $(1 + \sqrt{3})R$
- (D)  $(\sqrt{3} - 1)R$

**Solution:**

[Ans. C]

Circuit can be equivalently drawn as below

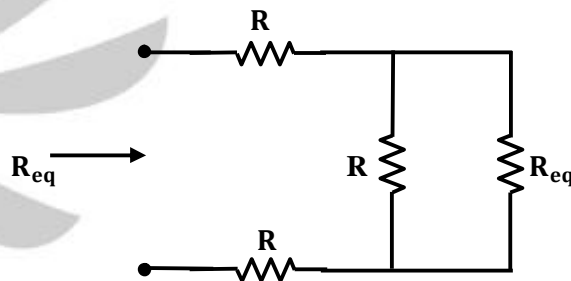


Fig. 1.64

$$R_{eq} = 2R + \frac{R R_{eq}}{(R + R_{eq})} \Rightarrow R_{eq}^2 + R R_{eq} = 2R^2 + 2R R_{eq} + R R_{eq}$$

$$\therefore R_{eq} = (1 + \sqrt{3})R$$

**Example:** Find the current through  $1\Omega$  resistor between terminals A and B in the following network

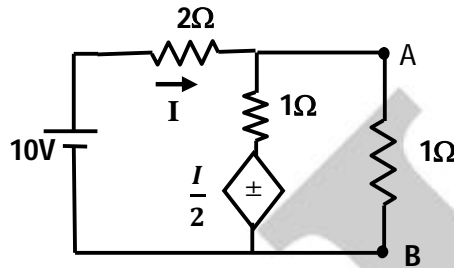


Fig. 1.65

**Solution:**

Equivalently, we have to find the Norton's equivalent circuit as seen from terminals A & B.

To find  $V_{OC}$ ,  $\frac{(V_{AB}-10)}{2} + \frac{(V_{AB}-\frac{I}{2})}{1} = 0$  and  $\frac{(10-V_{AB})}{2} = I$   
 $\Rightarrow I = \frac{20}{7}$  and  $V_{OC} = V_{AB} = \frac{30}{7} V$

To find  $I_{SC}$ ,  $I_{SC} = \frac{10}{2} + \frac{I}{2} = \frac{15}{2} A$

$R_N = \frac{V_{OC}}{I_{SC}} = \frac{30/7}{15/2} = \frac{4}{7}\Omega$

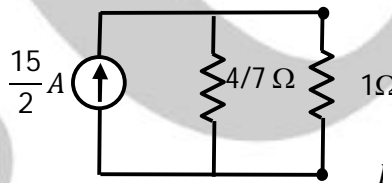


Fig. 1.66

$I_{AB} = \frac{\frac{15}{2} \times \frac{4}{7}}{\frac{11}{7}} = \frac{30}{11} A$

**Example:** Find the Norton's equivalent circuit of the following circuit as seen from terminals A and B.

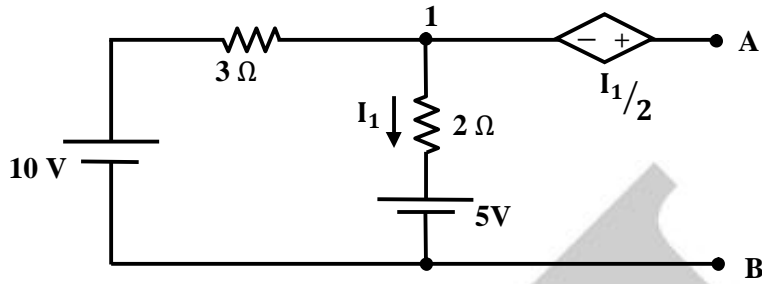
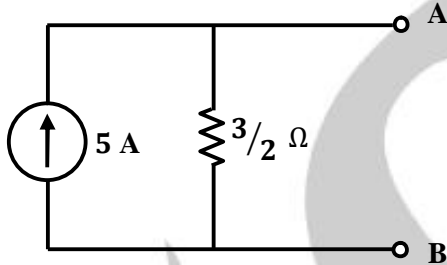
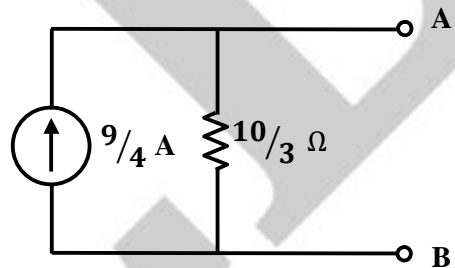


Fig. 1.67

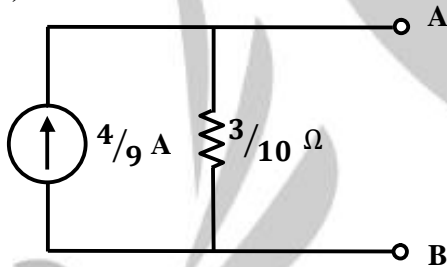
(A)



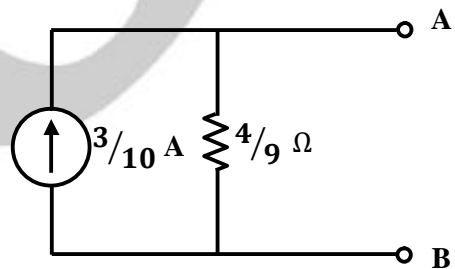
(C)



(B)



(D)



**Solution:**

[Ans. A]

For  $V_{OC}$ ,  $I_1 = 1A \Rightarrow V_{OC} = \frac{1}{2} + 2 + 5 = \frac{15}{2} V$

For  $I_{Sh}$ ,  $V_1 = -\frac{I_1}{2}$ ;  $V_1 - 5 = 2I_1 \Rightarrow I_1 = -2A$ ;  $V_1 = 1V$

$I_{Sh} = -I_1 + \frac{(1 - V_1)}{3} = 2 + 3 = 5 A$

$R_N = \frac{V_{OC}}{I_{Sh}} = \frac{3}{2} \Omega$

**Example:** Find the value of load resistance  $R_L$  for which maximum power is consumed in the following electrical circuit. Also find the corresponding power consumed in  $R_L$ .

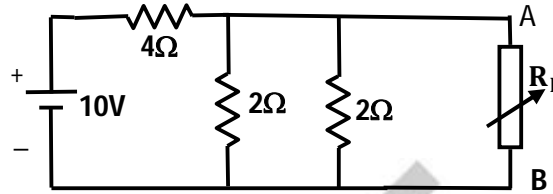


Fig. 1.68

**Solution:**

For maximum power transfer,  $R_L = R_{th} = (4 || 2 || 2) = \frac{4}{5} \Omega$

$$P_{max} = \frac{V_{th}^2}{4R_{th}} = \frac{4}{(4 \cdot \frac{4}{5})} = \frac{5}{4} \text{ watt } (\because V_{th} = 10 \times \frac{1}{5} = 2V)$$

**Example:** Find equivalent resistance as viewed from terminals A & B.

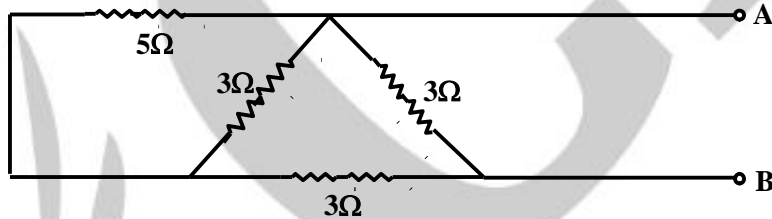


Fig. 1.69

**Solution:**

Apply Star-delta transformation,

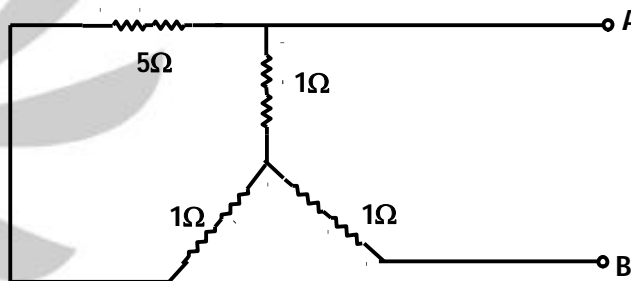


Fig. 1.70

$$R_{AB} = 1 + (1 || 6) = 1 + \frac{6}{7} = \frac{13}{7} \Omega$$

**Example:** Find the voltage  $V_1$  in the circuit shown below

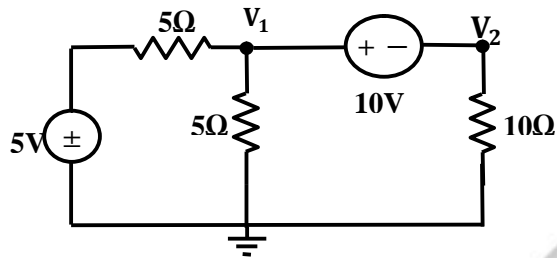


Fig. 1.71

- (A)  $-3V$   
 (B)  $2V$

- (C)  $8V$   
 (D)  $-6V$

**Solution:**

[Ans. B]

$$\frac{V_1 - 5}{5} + \frac{V_1}{5} + \frac{V_2}{10} = 0 \text{ and } V_1 - V_2 = 10.$$

$$V_1 \left( \frac{1}{5} + \frac{1}{5} + \frac{1}{10} \right) = 1 \Rightarrow V_1 = 2V$$