

---

# SAMPLE OF THE STUDY MATERIAL

## PART OF CHAPTER – 1

### STRESS AND STRAIN

#### 1.1 Stress & Strain

Stress is the internal resistance offered by the body per unit area. Stress is represented as force per unit area. Typical units of stress are  $\text{N/m}^2$ , ksi and MPa. There are two primary types of stresses: normal stress and shear stress. Normal stress,  $\sigma$ , is calculated when the force is normal to the surface area; whereas the shear stress,  $\tau$ , is calculated when the force is parallel to the surface area.

$$\sigma = \frac{P_{\text{normal\_to\_area}}}{A}$$

$$\tau = \frac{P_{\text{parallel\_to\_area}}}{A}$$

Linear strain (normal strain, longitudinal strain, axial strain),  $\epsilon$ , is a change in length per unit length. Linear strain has no units. Shear strain,  $\gamma$ , is an angular deformation resulting from shear stress. Shear strain may be presented in units of radians, percent, or no units at all.

$$\epsilon = \frac{\delta}{L}$$

$$\gamma = \frac{\delta_{\text{parallel\_to\_area}}}{\text{Height}} = \tan \theta \approx \theta \quad [\theta \text{ in radians}]$$

#### Example:

A composite bar consists of an aluminum section rigidly fastened between a bronze section and a steel section as shown in Fig. 1.1. Axial loads are applied at the positions indicated. Determine the stress in each section.

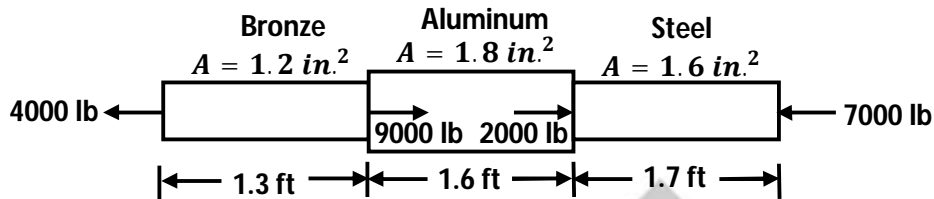

Figure 1.1

### Solution

To calculate the stresses, we must first determine the axial load in each section. The appropriate free-body diagrams are shown in Fig. 1.2 below from which we determine  $P_{br} = 4000$  lb (tension), and  $P_{st} = 7000$  lb (compression).

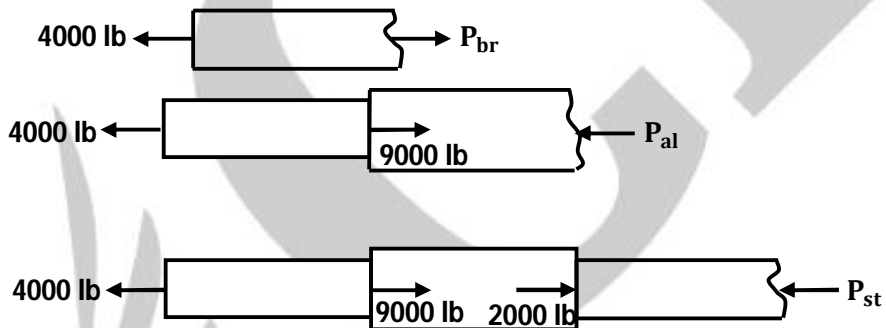

Figure 1.2

The stresses in each section are

$$\sigma_{br} = \frac{4000 \text{ lb}}{1.2 \text{ in.}^2} = 3330 \text{ psi} \quad (\text{tension}) \quad \left[ \sigma = \frac{P}{A} \right]$$

$$\sigma_{al} = \frac{5000 \text{ lb}}{1.8 \text{ in.}^2} = 2780 \text{ psi} \quad (\text{compression})$$

$$\sigma_{st} = \frac{7000 \text{ lb}}{1.6 \text{ in.}^2} = 4380 \text{ psi} \quad (\text{compression})$$

Note that neither the lengths of the sections nor the materials from which the sections are made affect the calculations of the stresses.

## 1.2 Hooke's Law: Axial and Shearing Deformations

Hooke's law is a simple mathematical relationship between elastic stress and strain: stress is proportional to strain. For normal stress, the constant of proportionality is the modulus of elasticity (Young's Modulus),  $E$ .

$$\sigma = E\varepsilon$$

The deformation,  $\delta$ , of an axially loaded member of original length  $L$  can be derived from Hooke's law. Tension loading is considered to be positive, compressive loading is negative. The sign of the deformation will be the same as the sign of the loading.

$$\delta = L\varepsilon = L\left(\frac{\sigma}{E}\right) = \frac{PL}{AE}$$

This expression for axial deformation assumes that the linear strain is proportional to the normal stress ( $\varepsilon = \sigma/E$ ) and that the cross-sectional area is constant.

When an axial member has distinct sections differing in cross-sectional area or composition, superposition is used to calculate the total deformation as the sum of individual deformations.

$$\delta = \sum \frac{PL}{AE} = P \sum \frac{L}{AE}$$

When one of the variables (e.g.,  $A$ ), varies continuously along the length,

$$\delta = \int \frac{PdL}{AE} = P \int \frac{dL}{AE}$$

The new length of the member including the deformation is given by

$$L_f = L + \delta$$

The algebraic deformation must be observed.

Hooke's law may also be applied to a plane element in pure shear. For such an element, the shear stress is linearly related to the shear strain, by the shear modulus (also known as the modulus of rigidity),  $G$ .

$$\tau = G\gamma$$

The relationship between shearing deformation,  $\delta_s$  and applied shearing force,  $V$  is then expressed by

$$\delta_s = \frac{VL}{AG}$$

**Example:**

If a tension test bar is found to taper uniformly from  $(D - a)$  to  $(D + a)$  diameter, prove that the error involved in using the mean diameter to calculate the Young's Modulus is  $\left(\frac{10a}{D}\right)^2$

**Solution:**

Let the two diameters be  $(D + a)$  and  $(D - a)$  as shown in Fig. 1.3. Let  $E$  be the Young's Modulus of elasticity. Let the extension of the member be  $\delta$ .

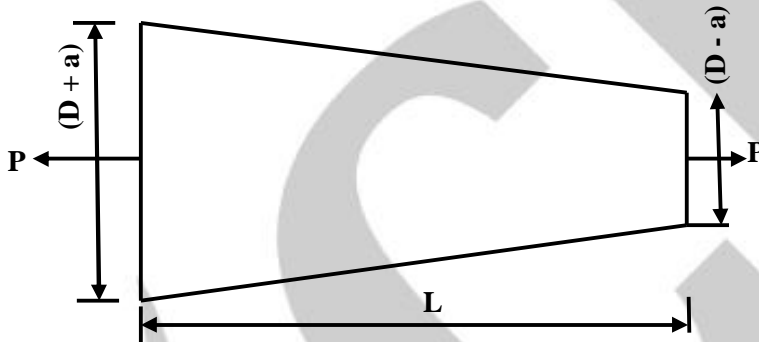

Figure 1.3

$$\text{Then, } \delta = \frac{4 PL}{\pi E (D+a)(D-a)}$$

$$\therefore E = \frac{4 PL}{\pi (D^2 - a^2) \delta}$$

If the mean diameter  $D$  is adopted, let  $E'$  be the computed Young's modulus.

$$\text{Then } \delta = \frac{4 PL}{\pi D^2 E'} \quad \therefore E' = \frac{4 PL}{\pi D^2 \delta}$$

$$\text{Hence, percentage error in computing Young's modulus} = \frac{E - E'}{E} \times 100$$

$$\begin{aligned} &= \frac{\frac{4 PL}{\pi (D^2 - a^2) \delta} - \frac{4 PL}{\pi D^2 \delta}}{\frac{4 PL}{\pi (D^2 - a^2) \delta}} \times 100 \\ &= \frac{\frac{1}{D^2 - a^2} - \frac{1}{D^2}}{\frac{1}{D^2 - a^2}} \times 100 \\ &= \left(\frac{10a}{D}\right)^2 \text{ percent.} \end{aligned}$$

**Example:**

A weight of 45 kN is hanging from three wires of equal length as shown in Fig. 1.4. The middle one is of steel and the two other wires are of copper. If the cross – section of each wire is 322 sq. mm, find the load shared by each wire. Take  $E_{\text{steel}} = 207 \text{ N/mm}^2$  and  $E_{\text{copper}} = 124.2 \text{ N/mm}^2$ .

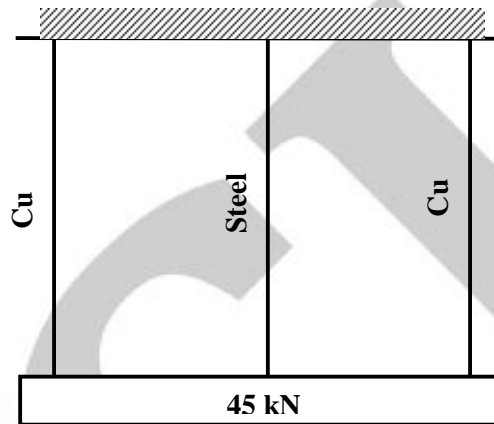

Figure 1.4

**Solution:**

Let

$P_c$  = load carried by the copper wire

$P_s$  = load carried by the steel wire

$f_c$  = stress in copper wire

$f_s$  = stress in steel wire

Then,  $P_c + P_s + P_c = 45000 \text{ N}$

or  $2P_c + P_s = 45000$

Also, strain in steel wire = strain in copper wire

Hence  $\frac{f_s}{E_s} = \frac{f_c}{E_c}$

or  $\frac{f_c}{f_s} = \frac{E_c}{E_s} = \frac{124.2}{207} = 0.6$

But,  $45000 = 2P_c + P_s = 2(f_c \times a) + (f_s \times a)$

$= 322 (2f_c + f_s) = 322(2 \times 0.6 f_s + f_s)$

$$\begin{aligned}\therefore f_s &= \frac{45000}{322 \times 2.2} = 63.5 \text{ N/mm}^2 \\ \therefore P_s &= f_s \times a = 63.5 \times 322 = 20.447 \text{ kN} \\ P_c &= \frac{45 - 20.447}{2} = 12.277 \text{ kN}\end{aligned}$$

**Example:**

Compute the total elongation caused by an axial load of 100 kN applied to a flat bar 20 mm thick, tapering from a width of 120 mm to 40 mm in a length of 10 m as shown in Fig. 1.5. Assume  $E = 200 \text{ GPa}$ . [1 Pa = 1N/m<sup>2</sup>]

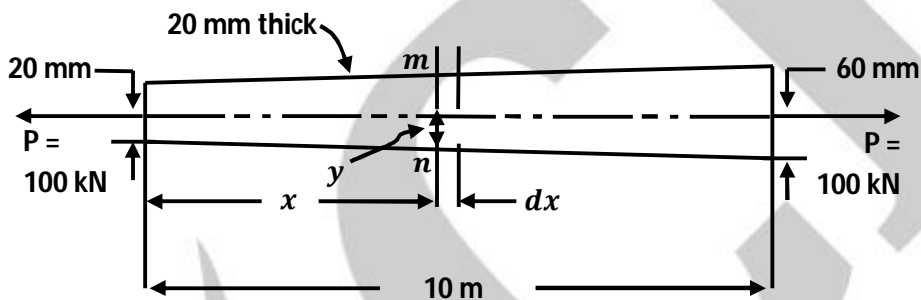

Figure 1.5

**Solution:**

Consider a differential length for which the cross-sectional area is constant. Then the total elongation is the sum of these infinitesimal elongations.

At section  $m-n$ , the half width  $y$  (mm) at a distance  $x$  (m) from the left end is found from geometry to be

$$\frac{y-20}{x} = \frac{60-20}{10} \quad \text{or} \quad y = (4x + 20) \text{ mm}$$

And the area at that section is

$$A = 20(2y) = (160x + 800) \text{ mm}^2$$

At section  $m-n$ , in a differential length  $dx$ , the elongation is given by

$$\begin{aligned}\left[ \delta = \frac{PL}{AE} \right] \quad d\delta &= \frac{(100 \times 10^3) dx}{(160x + 800)(10^{-6})(200 \times 10^9)} \\ &= \frac{0.500 dx}{160x + 800}\end{aligned}$$

from which the total elongation is

$$\delta = 0.500 \int_0^{10} \frac{dx}{160x + 800} = \frac{0.500}{160} [\ln(160x + 800)]_0^{10}$$

$$= (3.13 \times 10^{-3}) \ln \frac{2400}{800} = 3.44 \times 10^{-3} m = 3.44 \text{ mm}$$

### Example:

A compound tube is made by shrinking a thin steel tube on a thin brass tube.  $A_s$  and  $A_b$  are cross-sectional areas of steel and brass tubes respectively,  $E_s$  and  $E_b$  are the corresponding values of the Young's Modulus. Show that for any tensile load, the extension of the compound tube is equal to that of a single tube of the same length and total cross-sectional area but having a Young's Modulus of  $\left\{ \frac{E_s A_s + E_b A_b}{A_s + A_b} \right\}$ .

### Solution:

$$\frac{P_s}{E_s} = \frac{P_b}{E_b} = \text{strain} \quad \dots\dots (i)$$

Where  $P_s$  and  $P_b$  are stresses in steel and brass tubes respectively.

$$P_s A_s + P_b A_b = P \quad \dots\dots (ii)$$

where  $P$  – total load on the compound tube.

$$\text{From equations (i) and (ii); } \frac{E_s}{E_b} \cdot A_s P_b + P_b A_b = P$$

$$P_b \left[ \frac{E_s}{E_b} A_s + A_b \right] = P$$

$$P_b = \frac{E_b \cdot P}{E_s A_s + E_b A_b} \quad \dots\dots (iii)$$

Extension of the compound tube =  $dl$  = extension of steel or brass tube

$$dl = \frac{P_b}{E_b} \cdot l \quad \dots\dots (iv)$$

From equations (iii) and (iv);

$$dl = \frac{E_b P}{E_s A_s + E_b A_b} \times \frac{l}{E_b} = \frac{Pl}{E_s A_s + E_b A_b} \quad \dots\dots (v)$$

Let  $E$  be the Young's modulus of a tube of area  $(A_s + A_b)$  carrying the same load and undergoing the same extension

$$dl = \frac{Pl}{(A_s + A_b)E} \quad \dots\dots (vi)$$

equation (v) = (vi)

$$\therefore \frac{Pl}{E_s A_s + E_b A_b} = \frac{Pl}{(A_s + A_b)E} \text{ or } E = \frac{E_s A_s + E_b A_b}{A_s + A_b}$$

### Example:

The diameters of the brass and steel segments of the axially loaded bar shown in Fig. 1.6 are 30 mm and 12 mm respectively. The diameter of the hollow section of the brass segment is 20 mm. Determine:

- (i) The displacement of the free end;
- (ii) The maximum normal stress in the steel and brass

Take  $E_s = 210 \text{ GN/m}^2$  and  $E_b = 105 \text{ GN/m}^2$ .

### Solution:

In the Figure shown below,

$$A_s = \frac{\pi}{4} \times (12)^2 = 36\pi \text{ mm}^2 = 36\pi \times 10^{-6} \text{ m}^2$$

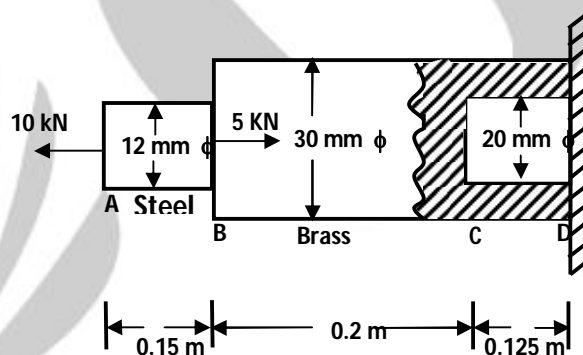

Figure 1.6

$$(A_b)_{BC} = \frac{\pi}{4} \times (30)^2 = 225\pi \text{ mm}^2 = 225\pi \times 10^{-6} \text{ m}^2$$

$$(A_b)_{CD} = \frac{\pi}{4} [(30)^2 - (20)^2] = 125\pi \text{ mm}^2 = 125\pi \times 10^{-6} \text{ m}^2$$

- (i) **The maximum normal stress in steel and brass:**

$$\sigma_s = \frac{10 \times 10^3}{36\pi \times 10^{-6}} \times 10^{-6} \text{ MN/m}^2 = \mathbf{88.42 \text{ MN/m}^2}$$

$$(\sigma_b)_{BC} = \frac{5 \times 10^3}{225\pi \times 10^{-6}} \times 10^{-6} \frac{\text{MN}}{\text{m}^2} = \mathbf{7.07 \text{ MN/m}^2}$$

$$(\sigma_b)_{CD} = \frac{5 \times 10^3}{125\pi \times 10^{-6}} \times 10^{-6} \text{ MN/m}^2 = \mathbf{12.73 \text{ MN/m}^2}$$

(ii) **The displacement of the free end:**

The displacement of the free end

$$\begin{aligned} \delta l &= (\delta l_s)_{AB} + (\delta l_b)_{BC} + (\delta l_b)_{CD} \\ &= \frac{88.42 \times 0.15}{210 \times 10^9 \times 10^{-6}} + \frac{7.07 \times 0.2}{105 \times 10^9 \times 10^{-6}} + \frac{12.73 \times 0.125}{105 \times 10^9 \times 10^{-6}} \quad \left[ \because \delta l = \frac{\sigma l}{E} \right] \\ &= 6.316 \times 10^{-5} + 1.347 \times 10^{-5} + 1.515 \times 10^{-5} \\ &= 9.178 \times 10^{-5} \text{ m or } \mathbf{0.09178 \text{ mm}} . \end{aligned}$$

**Example:**

A beam AB hinged at A is loaded at B as shown in Fig. 1.7. It is supported from the roof by a 2.4 cm long vertical steel bar CD which is 3.5 cm square for the first 1.8 m length and 2.5 cm square for the remaining length. Before the load is applied, the beam hangs horizontally. Take  $E_s = 210 \text{ GPa}$

Determine:

- (i) The maximum stress in the steel bar CD;
- (ii) The total elongation of the bar.

**Solution:**

Given:

$$A_2 = 2.5 \times 2.5 = 6.25 \text{ cm}^2 = 6.25 \times 10^{-4} \text{ m}^2;$$

$$A_1 = 3.5 \times 3.5 = 12.25 \times 10^{-4} \text{ m}^2; l_1 = 1.8 \text{ m}$$

$$l_2 = 0.6 \text{ m}$$

$$E_s = 210 \text{ GPa.}$$

Let P = The pull in the bar CD.

Then, taking moments about A, we get

$$P \times 0.6 = 60 \times 0.9$$

$$\therefore P = 90 \text{ kN}$$

(i) **The maximum stress in the steel bar CD,  $\sigma_{\max}$ :**

The stress shall be maximum in the portion DE of the steel bar CD.

$$\begin{aligned} \therefore \sigma_{\max} &= \frac{P}{A_2} = \frac{90 \times 10^3}{6.25 \times 10^{-4}} \times 10^{-6} \frac{\text{MN}}{\text{m}^2} \\ &= \mathbf{144 \text{ MN/m}^2} \end{aligned}$$

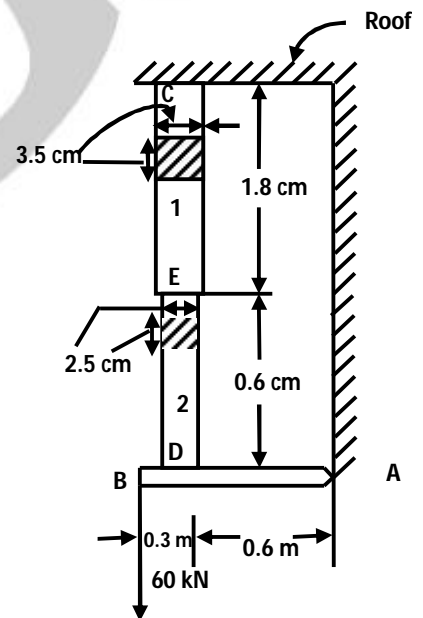

Figure 1.7

(ii) The total elongation of the bar CD,

$$\begin{aligned}
 \delta l &= \delta l_1 + \delta l_2 \\
 &= \frac{Pl_1}{A_1E} + \frac{Pl_2}{A_2E} = \frac{P}{E} \left[ \frac{l_1}{A_1} + \frac{l_2}{A_2} \right] \\
 &= \frac{90 \times 10^3}{210 \times 10^9} \left[ \frac{1.8}{12.25 \times 10^{-4}} + \frac{0.6}{6.25 \times 10^{-4}} \right] \\
 &= 0.428 \times 10^{-6} (1469.38 + 960) \\
 &= 0.001039 \text{ m} \approx \mathbf{1.04 \text{ mm}}
 \end{aligned}$$

### 1.3 Stress-Strain Diagram

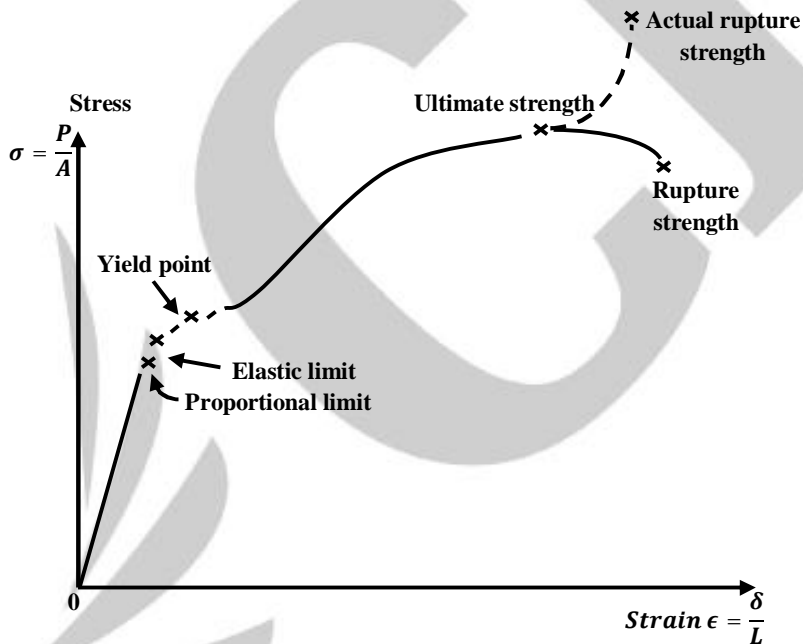

Figure 1.8

#### Proportional Limit:

It is the point on the stress strain curve up to which stress is proportional to strain.

#### Elastic Limit:

It is the point on the stress strain curve up to which material will return to its original shape when unloaded.

**Yield Point:**

It is the point on the stress strain curve at which there is an appreciable elongation or yielding of the material without any corresponding increase of load; indeed the load actually may decrease while the yielding occurs.

**Ultimate Strength:**

It is the highest ordinate on the stress strain curve.

**Rupture Strength:**

It is the stress at failure

**1.4 Poisson's Ratio: Biaxial and Triaxial Deformations**

Poisson's ratio,  $\nu$ , is a constant that relates the lateral strain to the axial strain for axially loaded members.

$$\nu = -\frac{\epsilon_{lateral}}{\epsilon_{axial}}$$

Theoretically, Poisson's ratio could vary from zero to 0.5, but typical values are 0.33 for aluminum and 0.3 for steel and maximum value of 0.5 for rubber.

Poisson's ratio permits us to extend Hooke's law of uniaxial stress to the case of biaxial stress. Thus if an element is subjected simultaneously to tensile stresses in x and y direction, the strain in the x direction due to tensile stress  $\sigma_x$  is  $\sigma_x/E$ . Simultaneously the tensile stress  $\sigma_y$  will produce lateral contraction in the x direction of the amount  $\nu\sigma_y/E$ , so the resultant unit deformation or strain in the x direction will be

$$\epsilon_x = \frac{\sigma_x}{E} - \nu \frac{\sigma_y}{E}$$

Similarly, the total strain in the y direction is

$$\epsilon_y = \frac{\sigma_y}{E} - \nu \frac{\sigma_x}{E}$$

Hooke's law can be further extended for three-dimensional stress-strain relationships and written in terms of the three elastic constants, E, G, and  $\nu$ . The following equations can be used to find the strains caused due to simultaneous action of triaxial tensile stresses:

$$\epsilon_x = \frac{1}{E} [\sigma_x - \nu(\sigma_y + \sigma_z)]$$

$$\epsilon_y = \frac{1}{E} [\sigma_y - \nu(\sigma_z + \sigma_x)]$$

$$\varepsilon_z = \frac{1}{E} [\sigma_z - \nu(\sigma_x + \sigma_y)]$$

$$\gamma_{xy} = \frac{\tau_{xy}}{G}$$

$$\gamma_{yz} = \frac{\tau_{yz}}{G}$$

$$\gamma_{zx} = \frac{\tau_{zx}}{G}$$

For an elastic isotropic material, the modulus of elasticity  $E$ , shear modulus  $G$ , and Poisson's ratio  $\nu$  are related by

$$G = \frac{E}{2(1+\nu)}$$

$$E = 2G(1+\nu)$$

The bulk modulus ( $K$ ) describes volumetric elasticity, or the tendency of an object's volume to deform when under pressure; it is defined as volumetric stress over volumetric strain, and is the inverse of compressibility. The bulk modulus is an extension of Young's modulus to three dimensions.

For an elastic, isotropic material, the modulus of elasticity  $E$ , bulk modulus  $K$ , and Poisson's ratio  $\nu$  are related by

$$E = 3K(1-2\nu)$$

### Example:

A thin spherical shell 1.5 m diameter with its wall of 1.25 cm thickness is filled with a fluid at atmospheric pressure. What intensity of pressure will be developed in it if 160 cu.cm more of fluid is pumped into it? Also, calculate the hoop stress at that pressure and the increase in diameter. Take  $E = 200$  GPa and  $\nu = 0.33$ .

### Solution:

At atmospheric pressure of fluid in the shell, there will not be any increase in its volume since the outside pressure too is atmospheric. But, when 160 cu. cm of fluid is admitted into it forcibly, the sphere shall have to increase its volume by 160 cu. cm.

$\therefore$  increase in volume = 160 cu. cm.

$$V = (4/3)\pi r^3 = (4/3)\pi \times 75^3 \text{ cu. cm.}$$

$$e_v = \frac{160}{V}$$

$$e_v = 3e_x$$

$$e_x = \frac{e_v}{3} = \frac{160}{3 \times V} = \frac{\text{increase in diameter}}{d}$$

$$\therefore \text{increase in diameter} = \frac{160 \times 150}{3 \times (4/3)\pi \times 75^3}$$

$$= \mathbf{0.00453 \text{ cm}}$$

## 1.5 Thermal stresses

Temperature causes bodies to expand or contract. Change in length due to increase in temperature can be expressed as

$$\Delta L = L.\alpha.\Delta t$$

Where, L is the length,  $\alpha$  ( $^{\circ}\text{C}$ ) is the coefficient of linear expansion, and  $\Delta t$  ( $^{\circ}\text{C}$ ) is the temperature change.

From the above equation thermal strain can be expressed as:

$$\epsilon = \frac{\Delta L}{L} = \alpha \Delta t$$

If a temperature deformation is permitted to occur freely no load or the stress will be induced in the structure. But in some cases it is not possible to permit these temperature deformations, which results in creation of internal forces that resist them. The stresses caused by these internal forces are known as thermal stresses.

When the temperature deformation is prevented, thermal stress developed due to temperature change can be given as:

$$\sigma = E.\alpha.\Delta t$$

### Example:

A copper rod of 15 mm diameter, 800 mm long is heated through  $50^{\circ}\text{C}$ . (a) What is its extension when free to expand? (b) Suppose the expansion is prevented by gripping it at both ends, find the stress, its nature and the force applied by the grips when one grip yields back by 0.5 mm.

$$\alpha_c = 18.5 \times 10^{-6} \text{ per } ^{\circ}\text{C}$$

$$E_c = 125 \text{ kN/mm}^2$$

**Solution:**

$$(a) \text{ Cross-sectional area of the rod} = \frac{\pi}{4} \times 15^2 = \frac{900\pi}{16} \text{ sq.mm}$$

Extension when the rod is free to expand

$$= \alpha T l = 18.5 \times 10^{-6} \times 50 \times 800 = 0.74 \text{ mm}$$

$$(b) \text{ When the grip yields by } 0.5 \text{ mm, extension prevented} = \alpha T l - 0.5 = 0.24 \text{ mm}$$

$$\text{Temperature strain} = \frac{0.24}{l}$$

$$\text{Temperature stress} = \frac{0.24}{800} \times 125 \times 10^3$$

$$= 37.5 \text{ N/mm}^2 \text{ (comp.)}$$

$$\text{Force applied} = 37.5 \times \frac{900\pi}{16} = 6627 \text{ N}$$

**Example:**

A steel band or a ring is shrunk on a tank of 1 metre diameter by raising the temperature of the ring through  $60^\circ\text{C}$ . Assuming the tank to be rigid, what should be the original inside diameter of the ring before heating? Also, calculate the circumferential stress in the ring when it cools back to the normal temperature on the tank.

$$\alpha_s = 10^{-6} \text{ per } ^\circ\text{C} \text{ and } E_s = 200 \text{ kN/mm}^2$$

**Solution:**

Let  $d$  mm be the original diameter at normal temperature and  $D$  mm, after being heated through  $60^\circ\text{C}$ .  $D$  should be, of course, equal to the diameter of the tank for slipping the ring on to it.

Circumference of the ring after heating =  $\pi D$  mm.

Circumference of the ring at normal temperature =  $\pi d$  mm

The ring after having been slipped on the tank cannot contract to  $\pi d$  and it cools down resulting in tensile stress in it.

$$\therefore \text{Contraction prevented} = \pi(D - d)$$

$$\text{Temperature strain} = \frac{\pi(D - d)}{\pi d} = \alpha_s T$$

$$\therefore \frac{D - d}{d} = \alpha_s T \text{ or } \frac{1000 - d}{d} = 10^{-6} \times 60$$

from which  $d = 999.4$  mm

circumferential temperature stress or stress due to prevention of contraction of the ring  
 $= \alpha_s TE = 10^{-6} \times 60 \times 2 \times 10^5 = 12 \text{ N/mm}^2$

**Example:**

A steel rod 2.5 m long is secured between two walls. If the load on the rod is zero at  $20^\circ\text{C}$ , compute the stress when the temperature drops to  $-20^\circ\text{C}$ . The cross-sectional area of the rod is  $1200 \text{ mm}^2$ ,  $\alpha = 11.7 \mu\text{m}/(\text{m}^\circ\text{C})$ , and  $E = 200 \text{ GPa}$ . Solve, assuming (a) that the walls are rigid and (b) that the walls spring together a total distance of  $0.500 \text{ mm}$  as the temperature drops.

**Solution:**

**Part a.** Imagine the rod is disconnected from the right wall. Temperature deformations can then freely occur. A temperature drop causes the contraction represented by  $\delta_T$  in Fig. 1.9. To reattach the rod to the wall, it will evidently require a pull  $P$  to produce the load deformation  $\delta_P$ . From the sketch of deformations, we see that  $\delta_T = \delta_P$ , or, in equivalent terms

$$\alpha(\Delta T)L = \frac{PL}{AE} = \frac{\sigma L}{E}$$

from which we have

$$\sigma = E\alpha(\Delta T) = (200 \times 10^9)(11.7 \times 10^{-6})(40) = 93.6 \times 10^6 \text{ N/m}^2 \\ = 93.6 \text{ MPa} \quad \text{Ans.}$$

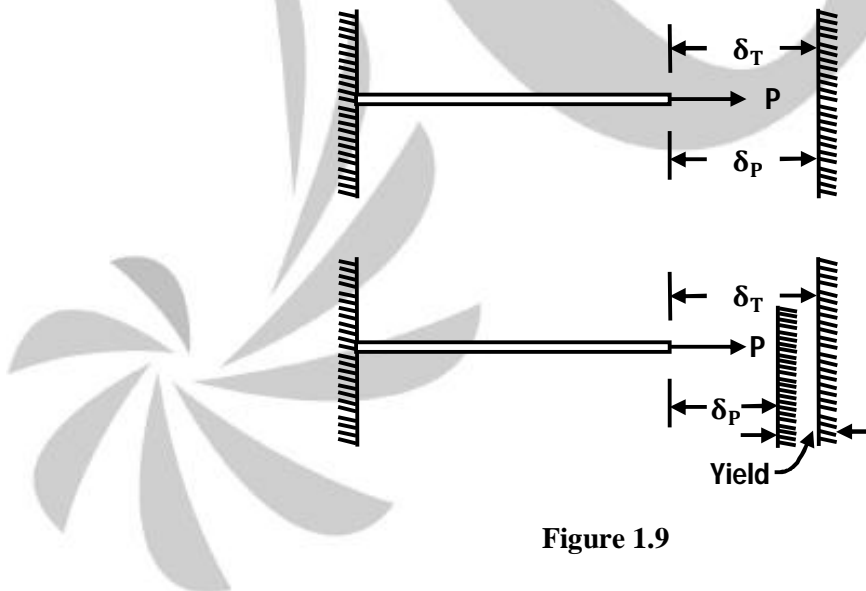

Figure 1.9

**Part b.** When the walls spring together, Fig. 1.9 shows that the free temperature contraction is equal to the sum of the load deformation and the yield of the walls.

Hence

$$\delta_T = \delta_p + \text{yield}$$

Replacing the deformations by equivalent terms, we obtain

$$\alpha L(\Delta T) = \frac{\sigma L}{E} + \text{yield}$$

$$\text{or } (11.7 \times 10^{-6})(2.5)(40) = \frac{\sigma(2.5)}{200 \times 10^9} + (0.5 \times 10^{-3})$$

from which we obtain

$$\sigma = 53.6 \text{ MPa} .$$

### Example:

A composite bar made up of aluminium and steel is firmly held between two unyielding supports as shown in Fig. 1.10.

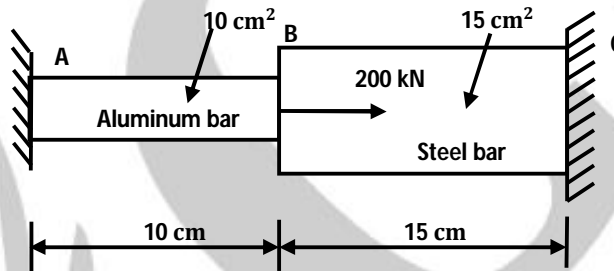

Figure 1.10

An axial load of 200 kN is applied at B at 50°C. Find the stresses in each material when the temperature is 100°C. Take  $E$  for aluminium and steel as 70 GN/m<sup>2</sup> and 210 GN/m<sup>2</sup> respectively. Coefficient of expansion for aluminium and steel are  $24 \times 10^{-6}$  per °C and  $11.8 \times 10^{-6}$  per °C respectively.

### Solution:

Given:

$A_{al} = 10 \text{ cm}^2 = 10 \times 10^{-4} \text{ m}^2$ ;  $A_s = 15 \text{ cm}^2 = 15 \times 10^{-4} \text{ m}^2$ ;  $l_{al} = 10 \text{ cm} = 0.1 \text{ m}$ ;  $l_s = 15 \text{ cm} = 0.15 \text{ m}$ ;  $t_{\text{initial}} = 50^\circ\text{C}$ ,  $t_{\text{final}} = 100^\circ\text{C}$ ; Load,  $P = 200 \text{ kN}$

$E_{al} = 70 \text{ GN/m}^2$ ;  $E_s = 210 \text{ GN/m}^2$ ;  $\alpha_{al} = 24 \times 10^{-6}$  per °C,  $\alpha_s = 11.8 \times 10^{-6}$  per °C.

**Stresses;  $\sigma_{al}$ ;  $\sigma_s$ ;**

Out of 200 kN load ( $P$ ) applied at B, let  $P_{al}$  kN be taken up by AB and  $(20 - P_{AB})$  kN by BC.

Since the supports are rigid,

Elongation of AB = contraction of BC.

$$\frac{P_{al} \times l_{al}}{A_{al} E_{al}} = \frac{P_s l_s}{A_s E_s} = \frac{(P - P_{al}) l_s}{A_s E_s}$$

$$\frac{(P_{al} \times 10^3) \times 0.1}{10 \times 10^{-4} \times 70 \times 10^9} = \frac{(200 - P_{al}) \times 10^3 \times 0.15}{15 \times 10^{-4} \times 210 \times 10^9}$$

$$\frac{P_{al}}{(200 - P_{al})} = \frac{10^3 \times 0.15 \times 10 \times 10^{-4} \times 70 \times 10^9}{10^3 \times 0.1 \times 15 \times 10^{-4} \times 210 \times 10^9} = 0.333$$

$$P_{al} = 66.67 - 0.333 P_{al}$$

$$\therefore P_{al} = 50 \text{ kN}$$

$$\text{Stress in aluminium, } (\sigma_{al})_1 = \frac{P_{al}}{A_{al}} = \frac{50 \times 10^3}{10 \times 10^{-4}} = 50 \text{ MN/m}^2 \text{ (Tensile)}$$

$$\text{Stress in steel, } (\sigma_s)_1 = \frac{P_s}{A_s} = \frac{P - P_{al}}{A_s} = \frac{(200 - 50) \times 10^3}{15 \times 10^{-4}} = 100 \text{ MN/m}^2 \text{ (Compressive)}$$

These are the stresses in the two materials (Aluminium and steel) at 50°C.

Now let the temperature be raised to 100°C. In order to determine the stresses due to rise of temperature, assume that the support at C is removed and expansion is allowed free.

$$\text{Rise of temperature} = t_{\text{final}} - t_{\text{initial}} = 100 - 50 = 50^\circ\text{C}$$

$$\text{Expansion of AB} = l_{al} \cdot \alpha_{al} \cdot t_{al} = 0.1 \times 24 \times 10^{-6} \times 50 = 120 \times 10^{-6} \text{ m} \quad \dots (i)$$

$$\text{Expansion of BC} = l_s \cdot \alpha_s \cdot t_s = 0.15 \times 11.8 \times 10^{-6} \times 50 = 88.5 \times 10^{-6} \text{ m.} \quad \dots (ii)$$

Let a load be applied at C which causes a total contraction equal to the total expansion and let C be attached to rigid supports.

If this load causes stress  $\sigma$  N/m<sup>2</sup> in BC, its value must be  $15 \times 10^{-4} \sigma$  and hence stress in AB

$$\text{must be } \frac{15 \times 10^{-4} \sigma}{10 \times 10^{-4}} = 1.5 \sigma \text{ N/m}^2$$

Total contraction caused by the load

$$= \frac{\sigma \times 0.15}{210 \times 10^9} + \frac{1.5 \sigma \times 0.1}{70 \times 10^9} \quad \dots (ii)$$

From eqns. (i) and (ii), we have

$$\frac{\sigma \times 0.15}{210 \times 10^9} + \frac{1.5 \sigma \times 0.1}{70 \times 10^9} = 120 \times 10^{-6} + 88.5 \times 10^{-6} = 208.5 \times 10^{-6}$$

$$\text{or } \frac{0.15 \sigma}{210} + \frac{0.15 \sigma}{70} = 10^9 \times 208.5 \times 10^{-6} = 208500$$

$$0.6 \sigma = 210 \times 208500 = 43785000$$

$$\therefore \sigma = 72.97 \times 10^6 \text{ N/m}^2 \text{ or } 72.97 \text{ MN/m}^2 \text{ (Compressive)}$$

$\therefore$  At  $100^\circ\text{C}$ ,

$$\text{Stress in aluminium, } \sigma_{al} = -(\sigma_{al})_1 + 1.5 \times 72.97$$

$$= -50 + 1.5 \times 72.97 = \mathbf{59.45 \text{ MN/m}^2 \text{ (comp.)}}$$

$$\text{Stress in steel, } \sigma_s = (\sigma_s)_1 + 72.97$$

$$= 100 + 72.97 = \mathbf{172.97 \text{ MN/m}^2 \text{ (comp.)}}$$

## 1.6 Thin-Walled Pressure Vessels

### Cylindrical shells

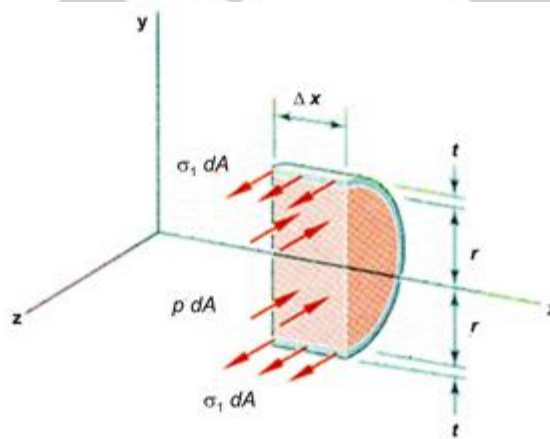

**Figure 1.11**

$$\sum F_z = 0: \sigma_1(2t\Delta x) - p(2r\Delta x) = 0$$

$$\text{Hoop stress or circumferential stress} = pr/t = pd/2t$$

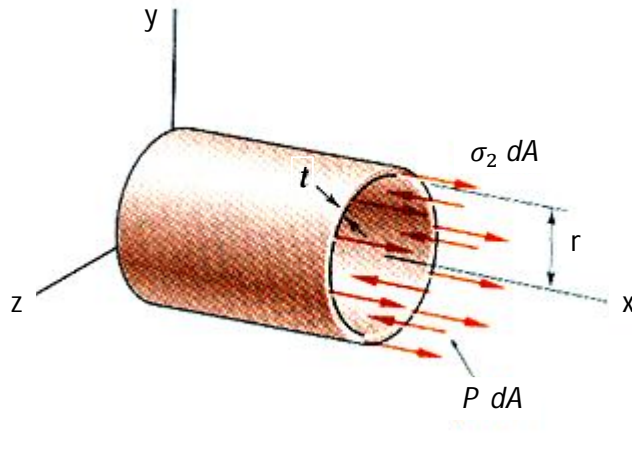

Figure 1.12

$$\sum F_x = 0: \sigma_2(2\pi r t) - p(2\pi r^2) = 0$$

Longitudinal stress =  $\frac{pr}{2t} = \frac{pd}{4t}$

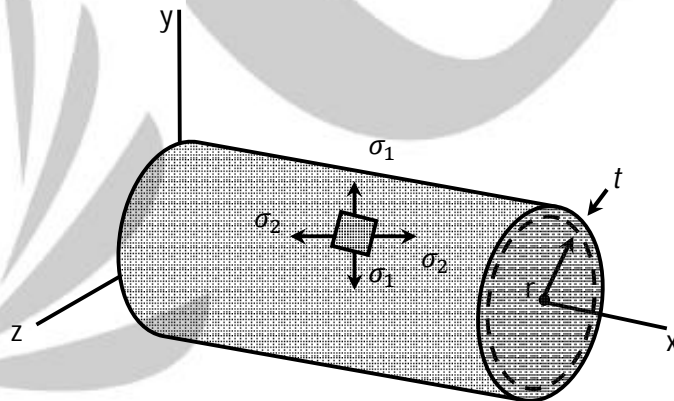

Figure 1.13

## Spherical shells

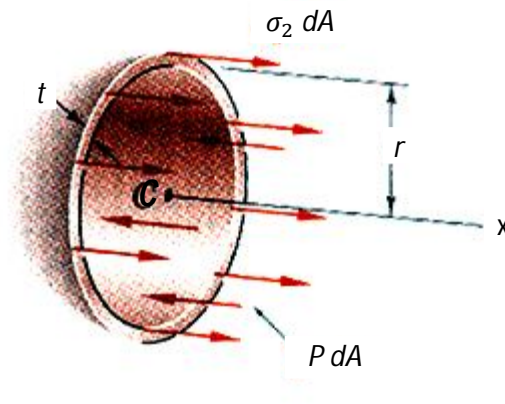

Figure 1.14

$$\sum F_x = 0: \sigma_2(2\pi r t) - p(2\pi r^2) = 0$$

$$\text{Hoop stress} = \text{longitudinal stress} = \sigma_1 = \sigma_2 = \frac{pr}{2t}$$

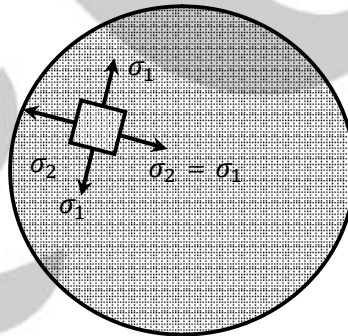

Figure 1.15

**Example:**

A cylindrical shell 900 mm long, 150 mm internal diameter, having a thickness of metal as 8 mm, is filled with a fluid at atmospheric pressure. If an additional 20000 mm<sup>3</sup> of fluid is pumped into the cylinder, find (i) the pressure exerted by the fluid on the cylinder and (ii) the hoop stress induced. Take  $E = 200 \text{ kN/mm}^2$  and  $\frac{1}{m} = 0.3$

**Solution:**

Let the internal pressure be  $p$ .  $\text{N/mm}^2$ .

$$\text{Hoop stress} = f_1 = \frac{pd}{2t} = \frac{p \times 150}{2 \times 8} = 9.375p \text{ N/mm}^2$$

$$\text{Longitudinal stress} = f_2 = \frac{f_1}{2} = 4.6875p \text{ N/mm}^2$$

$$\begin{aligned} \text{Circumferential strain} = e_1 &= \frac{1}{E} \left( f_1 - \frac{f_2}{m} \right) \\ &= \frac{P}{E} (9.375 - 0.3 \times 4.6875) \\ &= 7.96875 \frac{P}{E} \end{aligned}$$

$$\begin{aligned} \text{Longitudinal strain} = e_2 &= \frac{1}{E} \left( f_2 - \frac{f_1}{m} \right) \\ &= \frac{P}{E} (4.6875 - 0.3 \times 9.375) = 17.8125 \frac{P}{E} \end{aligned}$$

$$\text{Increase in volume} = \delta V = e_v V = 20000 \text{ mm}^3$$

$$\therefore 17.8125 \frac{P}{200 \times 10^3} \times \frac{\pi}{4} (150)^2 \times 900 = 20000$$

$$(i) \quad p = \mathbf{14.12 \text{ N/mm}^2}$$

$$(ii) \quad f_1 = \frac{pd}{2t} = \frac{14.12 \times 150}{2 \times 8} = \mathbf{132.4 \text{ N/mm}^2}$$

**1.7 Mohr's Circle**

Mohr's circle gives us a graphic tool by which, we can compare the different stress transformation states of a stress cube to a circle. Each different stress combination is described by a point around the circumference of the circle.

Compare the stress cube to a circle created using the circle offset

$$a \Rightarrow \sigma_{ave} = \frac{\sigma_x + \sigma_y}{2} \quad \text{and} \quad R = \sqrt{\left( \frac{\sigma_x - \sigma_y}{2} \right)^2 + \tau_{xy}^2}$$

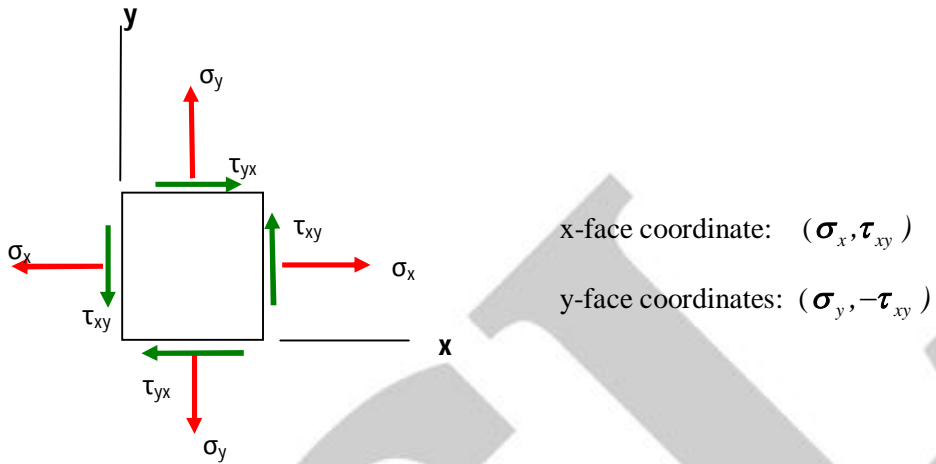

Figure 1.16

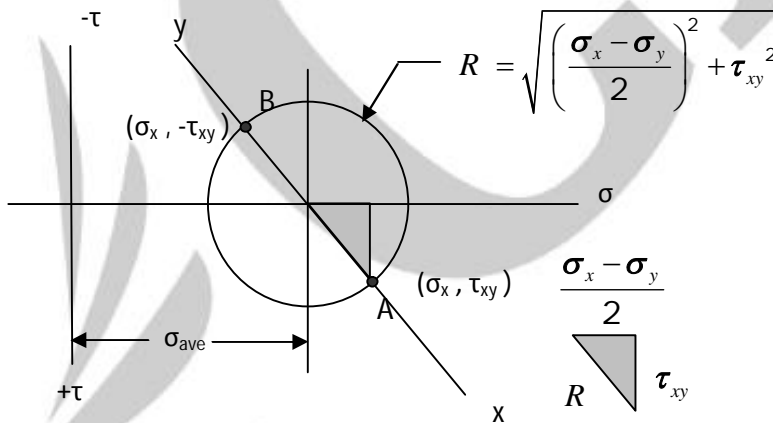

Figure 1.17

**Notes:**

- $+\tau$  (meaning counterclockwise around the cube) is downward
- $-\tau$  (meaning clockwise around the cube) is up on the axis
- A rotation angle of  $\theta$  on the stress cube shows up as  $2\theta$  on the circle diagram and rotates in the same direction. The largest and smallest values of  $\sigma$  are the principle stresses,  $\sigma_1$  and  $\sigma_2$ .

The largest shear stress,  $\tau_{\max}$  is equal to the radius of the circle,  $R$ . The center of the circle is located at the value of the average stress,  $\sigma_{\text{ave}}$

- If  $\sigma_1 = \sigma_2$  in magnitude and direction (nature) the Mohr circle will reduce into a point and no shear stress will be developed.
- If the plane contain only shear and no normal stress (pure shear), then origin and centre of the circle will coincide and maximum and minimum principal stress equal and opposite.

$$\sigma_1 = +\tau, \sigma_2 = -\tau$$

- The summation of normal stresses on any two mutually perpendicular planes remains constant.

$$\sigma_x + \sigma_y = \sigma_1 + \sigma_2$$

## 1.8 Applications: Thin-Walled Pressure Vessels

### Cylindrical shells:

Hoop stress or circumferential stress =  $\sigma_1 = \frac{pd}{2t}$

Longitudinal stress =  $\sigma_2 = \frac{pd}{4t}$

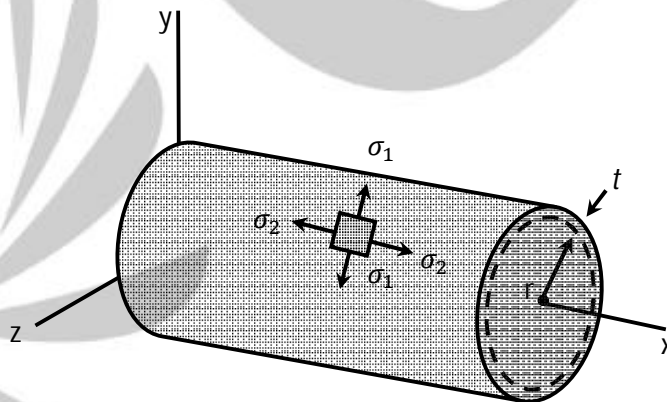

Figure 1.18

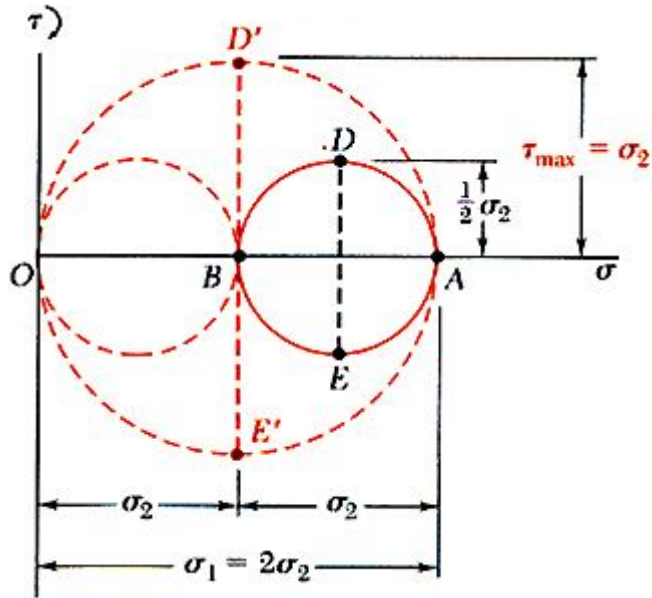

Figure 1.19

$$\tau_{max} = \frac{pd}{4t}$$

$$\tau_{max} \text{ (in plane)} = \frac{\sigma_2}{2} = \frac{pd}{8t}$$

**Spherical shells:**

Hoop stress = longitudinal stress =  $\sigma_1 = \sigma_2 = \frac{pd}{4t}$

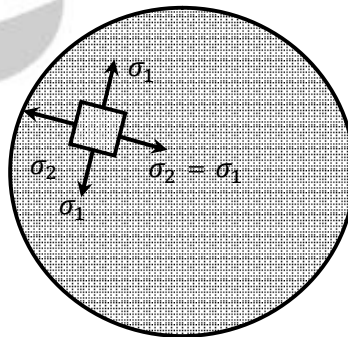

Figure 1.20

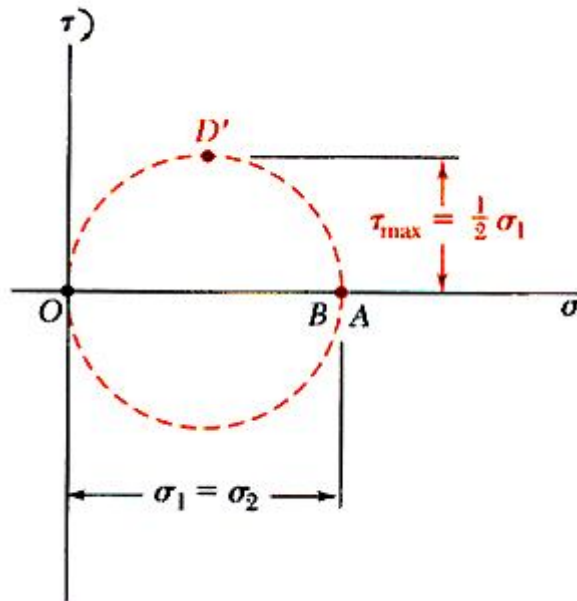

Figure 1.21

$$\tau_{\max} = \frac{\sigma_1}{2} = \frac{pd}{8t}$$

**Example:**

At a certain point a material is subjected to the following strains:

$$\varepsilon_x = 400 \times 10^{-6}; \varepsilon_y = 200 \times 10^{-6};$$

$$\gamma_{xy} = 350 \times 10^{-6}.$$

Determine the magnitudes of the principal strains, the directions of the principal strain axes and the strain on an axis inclined at  $30^\circ$  clockwise to the x-axis.

**Solution:**

Mohr's strain circle is as shown in **Figure 1.22**.

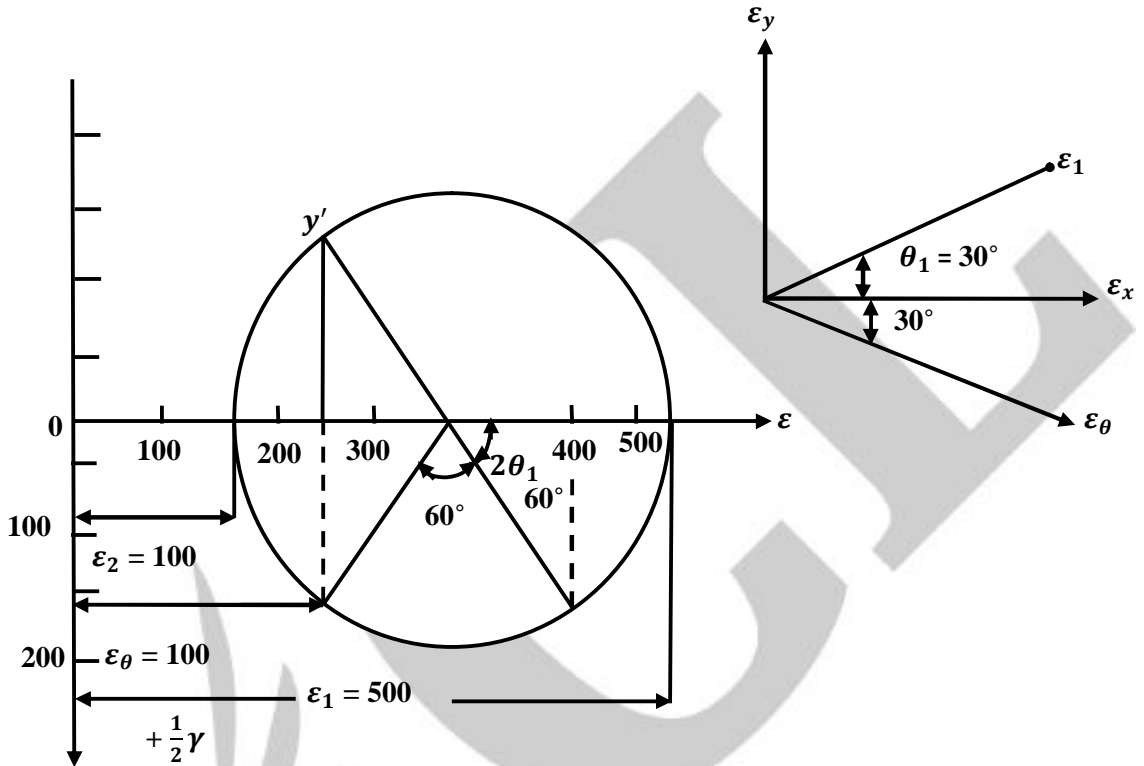

**Figure 1.22**

By measurement:

$$\varepsilon_1 = 500 \times 10^{-6} \quad \varepsilon_2 = 100 \times 10^{-6}$$

$$\theta_1 = \frac{60^\circ}{2} = 30^\circ \quad \theta_2 = 90^\circ + 30^\circ = 120^\circ$$

$$\varepsilon_{30} = 200 \times 10^{-6}$$

the angles being measured counterclockwise from the direction of  $\varepsilon_x$ .

**Example:**

Draw Mohr's circle for a 2-dimensional stress field subjected to (a) pure shear (b) pure biaxial tension, (c) pure uniaxial tension and (d) pure uniaxial compression.

**Solution:**

Mohr's circles for 2-dimensional stress field subjected to pure shear, pure biaxial tension, pure uniaxial compression and pure uniaxial tension are shown in Fig. 1.23(a) to 1.23(d).

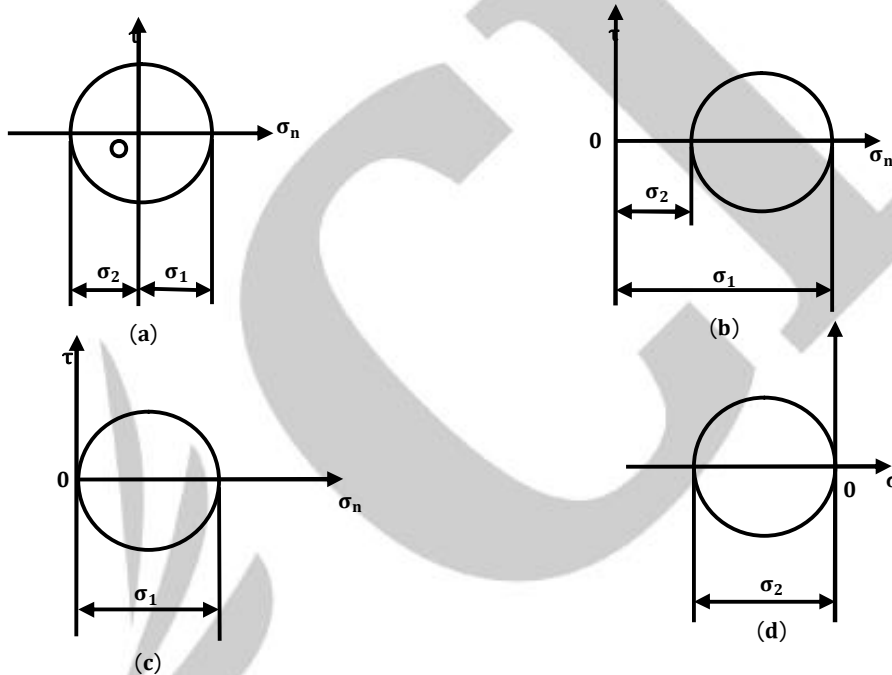

Figure 1.23

**Example:**

A thin cylinder of 100 mm internal diameter and 5 mm thickness is subjected to an internal pressure of 10 MPa and a torque of 2000 Nm. Calculate the magnitudes of the principal stresses.

**Solution:**

Given:

$$d = 100 \text{ mm} = 0.1 \text{ m}; t = 5 \text{ mm} = 0.005 \text{ m}; D = d + 2t = 0.1 + 2 \times 0.005 = 0.11 \text{ m},$$

$$p = 10 \text{ MPa}, 10 \times 10^6 \text{ N/m}^2; T = 2000 \text{ Nm}.$$

**Principal stresses,  $\sigma_1, \sigma_2$ :**

$$\text{Longitudinal stress, } \sigma_1 = \sigma_x = \frac{pd}{4t} = \frac{10 \times 10^6 \times 0.1}{4 \times 0.005} = 50 \times 10^6 \text{ N/m}^2 = 50 \text{ MN/m}^2$$

$$\text{Circumferential stress, } \sigma_c = \sigma_y = \frac{pd}{2t} = \frac{10 \times 10^6 \times 0.1}{2 \times 0.005} = 100 \text{ MN/m}^2$$

To find the shear stress, using the relation,

$$\frac{T}{I_p} = \frac{\tau}{R}, \text{ we have}$$

$$\tau = \tau_{xy} = \frac{TR}{I_p} = \frac{T \times R}{\frac{\pi}{32}(D^4 - d^4)} = \frac{2000 \times (0.05 + 0.005)}{\frac{\pi}{32}(0.11^4 - 0.1^4)} = 24.14 \text{ MN/m}^2$$

Principal stresses are calculated as follows:

$$\begin{aligned} \sigma_1, \sigma_2 &= \frac{\sigma_x + \sigma_y}{2} \pm \sqrt{\left[\frac{\sigma_x - \sigma_y}{2}\right]^2 + (\tau_{xy})^2} \\ &= \frac{50 + 100}{2} \pm \sqrt{\left[\frac{50 - 100}{2}\right]^2 + (24.14)^2} \\ &= 75 \pm 34.75 = 109.75 \text{ and } 40.25 \text{ MN/m}^2 \end{aligned}$$

Hence,  $\sigma_1$  (Major principal stress) = **109.75 MN/m<sup>2</sup>; (Ans.)**

$\sigma_2$  (minor principal stress) = **40.25 MN/m<sup>2</sup> (Ans.)**

**Example:**

A solid shaft of diameter 30 mm is fixed at one end. It is subject to a tensile force of 10 kN and a torque of 60 Nm. At a point on the surface of the shaft, determine the principle stresses and the maximum shear stress.

**Solution:**

Given:  $D = 30 \text{ mm} = 0.03 \text{ m}$ ;  $P = 10 \text{ kN}$ ;  $T = 60 \text{ Nm}$

**Principal stresses ( $\sigma_1, \sigma_2$ ) and maximum shear stress ( $\tau_{\max}$ ):**

$$\text{Tensile stress, } \sigma_t = \sigma_x = \frac{10 \times 10^3}{\frac{\pi}{4} \times 0.03^2} = 14.15 \times 10^6 \text{ N/m}^2 \text{ or } 14.15 \text{ MN/m}^2$$



Figure 1.24

As per torsion equation,  $\frac{T}{I_p} = \frac{\tau}{R}$

$$\therefore \text{Shear stress, } I = \frac{TR}{I_p} = \frac{TR}{\frac{\pi}{32}D^4} = \frac{60 \times 0.015}{\frac{\pi}{32} \times (0.03)^4} = 11.32 \times 10^6 \text{ N/m}^2 \text{ or } 11.32 \text{ MN/m}^2$$

The principal stresses are calculated by using the relations:

$$\sigma_1, \sigma_2 = \left[ \frac{\sigma_x + \sigma_y}{2} \right] \pm \sqrt{\left[ \frac{\sigma_x - \sigma_y}{2} \right]^2 + \tau_{xy}^2}$$

Here  $\sigma_x = 14.15 \text{ MN/m}^2$ ,  $\sigma_y = 0$ ;  $\tau_{xy} = \tau = 11.32 \text{ MN/m}^2$

$$\therefore \sigma_1, \sigma_2 = \frac{14.15}{2} \pm \sqrt{\left[ \frac{14.15}{2} \right]^2 + (11.32)^2}$$

$$= 7.07 \pm 13.35 = 20.425 \text{ MN/m}^2, -6.275 \text{ MN/m}^2.$$

Hence, major principal stress,  $\sigma_1 = 20.425 \text{ MN/m}^2$  (tensile) (Ans.)

Minor principal stress,  $\sigma_2 = 6.275 \text{ MN/m}^2$  (compressive) (Ans.)

$$\text{Maximum shear stress, } \tau_{\max} = \frac{\sigma_1 - \sigma_2}{2} = \frac{24.425 - (-6.275)}{2} = 13.35 \text{ MN/m}^2 \text{ (Ans.)}$$

### Example:

A thin cylinder with closed ends has an internal diameter of 50 mm and a wall thickness of 2.5 mm. It is subjected to an axial pull of 10 kN and a torque of 500 Nm while under an internal pressure of 6 MN/m<sup>2</sup>.

- (i) Determine the principal stresses in the tube and the maximum shear stress.
- (ii) Represent the stress configuration on a square element taken in the load direction with direction and magnitude indicated; (schematic)

**Solution:**

Given:  $d = 50 \text{ mm} = 0.05 \text{ m}$   $D = d + 2t = 50 + 2 \times 2.5 = 55 \text{ mm} = 0.055 \text{ m}$ ;

Axial pull,  $P = 10 \text{ kN}$ ;  $T = 500 \text{ Nm}$ ;  $p = 6 \text{ MN/m}^2$

(i) **Principal stress ( $\sigma_1, \sigma_2$ ) in the tube and the maximum shear stress ( $\tau_{\max}$ ):**

$$\sigma_x = \frac{pd}{4t} + \frac{P}{\pi dt} = \frac{6 \times 10^6 \times 0.05}{4 \times 2.5 \times 10^{-3}} + \frac{10 \times 10^3}{\pi \times 0.05 \times 2.5 \times 10^{-3}}$$

$$= 30 \times 10^6 + 25.5 \times 10^6 = 55.5 \times 10^6 \text{ N/m}^2$$

$$\sigma_y = \frac{pd}{2t} = \frac{6 \times 10^6 \times 0.05}{2 \times 2.5 \times 10^{-3}} = 60 \times 10^6$$

Principal stresses are given by the relations:

$$\sigma_1, \sigma_2 = \left[ \frac{\sigma_x + \sigma_y}{2} \right] \pm \sqrt{\left[ \frac{\sigma_x - \sigma_y}{2} \right]^2 + \tau_{xy}^2}$$

We know that,  $\frac{T}{J} = \frac{\tau}{R}$

where  $J = \frac{\pi}{32} (D^4 - d^4) = \frac{\pi}{32} [(0.055)^4 - (0.05)^4] = 2.848 \times 10^{-7} \text{ m}^4$

$$\frac{500}{2.848 \times 10^{-7}} = \frac{\tau}{(0.055/2)}$$

$$\text{or, } \tau = \frac{500 \times (0.055/2)}{2.848 \times 10^{-7}} = 48.28 \times 10^6 \text{ N/m}^2$$

Now, substituting the various values in eqn. (i), we have

$$\sigma_1, \sigma_2 = \left[ \frac{55.5 \times 10^6 + 60 \times 10^6}{2} \right] \pm \sqrt{\left[ \frac{55.5 \times 10^6 - 60 \times 10^6}{2} \right]^2 + (48.28 \times 10^6)^2}$$

$$= \frac{(55.5 + 60) \times 10^6}{2} \pm \sqrt{4.84 \times 10^{12} + 2330.96 \times 10^{12}}$$

$$= 57.75 \times 10^6 \pm 48.33 \times 10^6 = 106.08 \text{ MN/m}^2, 9.42 \text{ MN/m}^2$$

Hence, principal stress are:  $\sigma_1 = 106.08 \text{ MN/m}^2$  ;  $\sigma_2 = 9.42 \text{ MN/m}^2$  Ans.

Maximum shear stress,  $\tau_{\max} = \frac{\sigma_1 - \sigma_2}{2} = \frac{106.08 - 9.42}{2} = 48.33 \text{ MN/m}^2$  Ans.

(ii) Stress configuration on a square element:

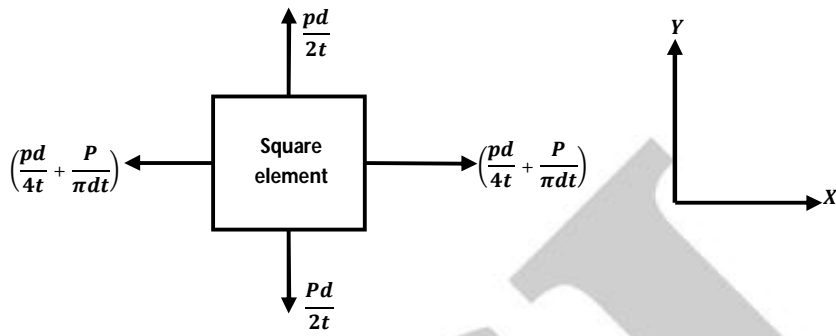

Figure 1.25