

PART A – MATHEMATICS

1. The line L given by $\frac{x}{5} + \frac{y}{b} = 1$ passes through the point (13, 32). The line K is parallel to L and has the equation $\frac{x}{c} + \frac{y}{3} = 1$. Then the distance between L and K is
- (1) $\frac{23}{\sqrt{17}}$ (2) $\frac{23}{\sqrt{15}}$
 (3) $\sqrt{17}$ (4) $\frac{17}{\sqrt{15}}$
2. The number of 3×3 non-singular matrices, with four entries as 1 and all other entries as 0, is
- (1) at least 7 (2) less than 4
 (3) 5 (4) 6
3. Let $f : \mathbb{R} \rightarrow \mathbb{R}$ be defined by
- $$f(x) = \begin{cases} k = 2x, & \text{if } x \leq -1 \\ 2x + 3, & \text{if } x > -1 \end{cases}$$
- If f has a local minimum at $x = -1$, then a possible value of k is
- (1) -1 (2) 1
 (3) 0 (4) $-\frac{1}{2}$

Directions : Questions number 4 to 8 are Assertion–Reason type questions. Each of these questions contains two statements.

Statement-1 : (Assertion) and
Statement-2 : (Reason)

Each of these questions also has four alternative choices, only one of which is the correct answer. You have to select the correct choice.

4. Four numbers are chosen at random (without replacement) from the set $\{1, 2, 3, \dots, 20\}$.
Statement-1 : The probability that the chosen numbers when arranged in some order will form an AP is $\frac{1}{85}$.

Statement-2 : If four chosen numbers form an AP, then the set of all possible values of common difference is $\{\pm 1, \pm 2, \pm 3, \pm 4, \pm 5\}$

- (1) Statement-1 is false, Statement-2 is true.
 (2) Statement-1 is true, Statement-2 is true; Statement-2 is a correct explanation for Statement-1.
 (3) Statement-1 is true, Statement-2 is true; Statement-2 is **not** a correct explanation for Statement-1.
 (4) Statement-1 is true, Statement-2 is false.
5. Let A be a 2×2 matrix with non-zero entries and let $A^2 = I$, where I is 2×2 identity matrix. Define
 $\text{Tr}(A)$ = sum of diagonal elements of A and
 $|A|$ = determinant of matrix A .
Statement-1 : $\text{Tr}(A) = 0$.
Statement-2 : $|A| = 1$.
 (1) Statement-1 is false, Statement-2 is true.
 (2) Statement-1 is true, Statement-2 is true; Statement-2 is a correct explanation for Statement-1.
 (3) Statement-1 is true, Statement-2 is true; Statement-2 is **not** a correct explanation for Statement-1.
 (4) Statement-1 is true, Statement-2 is false.
6. Let $f : \mathbb{R} \rightarrow \mathbb{R}$ be a continuous function defined by
- $$f(x) = \frac{1}{e^x + 2e^{-x}}.$$
- Statement-1 :** $f(c) = \frac{1}{3}$, for some $c \in \mathbb{R}$.
Statement-2 : $0 < f(x) \leq \frac{1}{2\sqrt{2}}$, for all $x \in \mathbb{R}$.
 (1) Statement-1 is false, Statement-2 is true.
 (2) Statement-1 is true, Statement-2 is true; Statement-2 is a correct explanation for Statement-1.
 (3) Statement-1 is true, Statement-2 is true; Statement-2 is **not** a correct explanation for Statement-1.
 (4) Statement-1 is true, Statement-2 is false.

7. **Statement-1** : The point A(3, 1, 6) is the mirror image of the point B(1, 3, 4) in the plane $x - y + z = 5$.

Statement-2 : The plane $x - y + z = 5$ bisects the line segment joining A(3, 1, 6) and B(1, 3, 4)

- (1) Statement-1 is false, Statement-2 is true.
 (2) Statement-1 is true, Statement-2 is true; Statement-2 is a correct explanation for Statement-1.
 (3) Statement-1 is true, Statement-2 is true; Statement-2 is **not** a correct explanation for Statement-1.
 (4) Statement-1 is true, Statement-2 is false.

8. Let $S_1 = \sum_{j=1}^{10} j(j-1)^{10} C_j$, $S_2 = \sum_{j=1}^{10} j^{10} C_j$ and $S_3 = \sum_{j=1}^{10} j^2 {}^{10} C_j$.

Statement-1 : $S_3 = 55 \times 2^9$

Statement-2 : $S_1 = 90 \times 2^8$ and $S_2 = 10 \times 2^8$.

- (1) Statement-1 is false, Statement-2 is true.
 (2) Statement-1 is true, Statement-2 is true; Statement-2 is a correct explanation for Statement-1.
 (3) Statement-1 is true, Statement-2 is true; Statement-2 is **not** a correct explanation for Statement-1.
 (4) Statement-1 is true, Statement-2 is false.

9. A line AB in three-dimensional space makes angles 45° and 120° with the positive x-axis and the positive y-axis respectively. If AB makes an acute angle θ with the positive z-axis, then θ equals

- (1) 75° (2) 30°
 (3) 45° (4) 60°

10. For a regular polygon, let r and R be the radii of the inscribed and the circumscribed circles. A **false** statement among the following is

- (1) There is a regular polygon with $\frac{r}{R} = \frac{\sqrt{3}}{2}$
 (2) There is a regular polygon with $\frac{r}{R} = \frac{1}{2}$

(3) There is a regular polygon with $\frac{r}{R} = \frac{1}{\sqrt{2}}$

(4) There is a regular polygon with $\frac{r}{R} = \frac{2}{3}$

11. Let $\cos(\alpha + \beta) = \frac{4}{5}$ and let $\sin(\alpha - \beta) = \frac{5}{13}$,

where $0 \leq \alpha, \beta \leq \frac{\pi}{4}$. Then $\tan 2\alpha =$

- (1) $\frac{20}{7}$ (2) $\frac{25}{16}$
 (3) $\frac{56}{33}$ (4) $\frac{19}{12}$

12. Let S be a non-empty subset of R. Consider the following statement :

P : There is a rational number $x \in S$ such that $x > 0$.

Which of the following statements is the \neg negation of the statement P?

- (1) $x \in S$ and $x \leq 0 \Rightarrow x$ is not rational.
 (2) There is a rational number $x \in S$ such that $x \leq 0$
 (3) There is no rational number $x \in S$ such that $x \leq 0$
 (4) Every rational number $x \in S$ satisfies $x \leq 0$

13. Let $p(x)$ be a function defined on R such that $p'(x) = p'(1-x)$, for all $x \in [0, 1]$, $p(0) = 1$ and

$p(1) = 41$. Then $\int_0^1 p(x) dx$ equals

- (1) 42 (2) $\sqrt{41}$
 (3) 21 (4) 41

14. A person is to count 4500 currency notes. Let a_n denote the number of notes he counts in the n^{th} minute. If $a_1 = a_2 = \dots = a_{10} = 150$ and a_{10}, a_{11}, \dots are in an AP with common difference -2 , then the time taken by him to count all notes is

- (1) 135 minutes (2) 24 minutes
 (3) 34 minutes (4) 125 minutes

15. Let $f : \mathbb{R} \rightarrow \mathbb{R}$ be a positive increasing function with $\lim_{x \rightarrow \infty} \frac{f(3x)}{f(x)} = 1$. Then $\lim_{x \rightarrow \infty} \frac{f(2x)}{f(x)} =$
- (1) 3 (2) 1
(3) $\frac{2}{3}$ (4) $\frac{3}{2}$
16. Solution of the differential equation $\cos x \, dy = y(\sin x - y) \, dx$, $0 < x < \frac{\pi}{2}$ is
- (1) $\tan x = (\sec x + c) y$
(2) $\sec x = (\tan x + c) y$
(3) $y \sec x = \tan x + c$
(4) $y \tan x = \sec x + c$
17. The area bounded by the curves $y = \cos x$ and $y = \sin x$ between the ordinates $x = 0$ and $x = \frac{3\pi}{2}$ is
- (1) $4\sqrt{2} + 1$ (2) $4\sqrt{2} - 2$
(3) $4\sqrt{2} + 2$ (4) $4\sqrt{2} - 1$
18. The equation of the tangent to the curve $y = x + \frac{4}{x^2}$, that is parallel to the x-axis, is
- (1) $y = 3$ (2) $y = 0$
(3) $y = 1$ (4) $y = 2$
19. Let $f : (-1, 1) \rightarrow \mathbb{R}$ be a differentiable function with $f(0) = -1$ and $f'(0) = 1$. Let $g(x) = [f(2f(x) + 2)]^2$. Then $g'(0) =$
- (1) -2 (2) 4
(3) -4 (4) 0
20. There are two urns. Urn A has 3 distinct red balls and urn B has 9 distinct blue balls. From each urn two balls are taken out at random and then transferred to the other. The number of ways in which this can be done is
- (1) 108 (2) 3
(3) 36 (4) 66
21. Consider the system of linear equations :
 $x_1 + 2x_2 + x_3 = 3$
 $2x_1 + 3x_2 + x_3 = 3$
 $3x_1 + 5x_2 + 2x_3 = 1$
 The system has
 (1) no solution
 (2) infinite number of solutions
 (3) exactly 3 solutions
 (4) a unique solution
22. Let $\vec{a} = \hat{j} - \hat{k}$ and $\vec{c} = \hat{i} - \hat{j} - \hat{k}$. Then the vector \vec{b} satisfying $\vec{a} \times \vec{b} + \vec{c} = \vec{0}$ and $\vec{a} \cdot \vec{b} = 3$ is
- (1) $\hat{i} + \hat{j} - 2\hat{k}$ (2) $-\hat{i} + \hat{j} - 2\hat{k}$
(3) $2\hat{i} - \hat{j} + 2\hat{k}$ (4) $\hat{i} - \hat{j} - 2\hat{k}$
23. For two data sets, each of size 5, the variances are given to be 4 and 5 and the corresponding means are given to be 2 and 4, respectively. The variance of the combined data set is
- (1) $\frac{13}{2}$ (2) $\frac{5}{2}$
(3) $\frac{11}{2}$ (4) 6
24. The circle $x^2 + y^2 = 4x + 8y + 5$ intersects the line $3x - 4y = m$ at two distinct points if
- (1) $35 < m < 85$ (2) $-85 < m < -35$
(3) $-35 < m < 15$ (4) $15 < m < 65$
25. An urn contains nine balls of which three are red, four are blue and two are green. Three balls are drawn at random without replacement from the urn. The probability that the three balls have different colours is
- (1) $\frac{2}{23}$ (2) $\frac{1}{3}$
(3) $\frac{2}{7}$ (4) $\frac{1}{21}$
26. If two tangents drawn from a point P to the parabola $y^2 = 4x$ are at right angles, then the locus of P is
- (1) $2x - 1 = 0$ (2) $x = 1$
(3) $2x + 1 = 0$ (4) $x = -1$

27. If the vectors $\vec{a} = \hat{i} - \hat{j} + 2\hat{k}$, $\vec{b} = 2\hat{i} + 4\hat{j} + \hat{k}$ and $\vec{c} = \lambda\hat{i} + \hat{j} + \mu\hat{k}$ are mutually orthogonal, then $(\lambda, \mu) =$
- (1) (3, -2) (2) (-3, 2)
 (3) (2, -3) (4) (-2, 3)
28. The number of complex numbers z such that $|z - 1| = |z + 1| = |z - i|$ equals
- (1) ∞ (2) 0
 (3) 1 (4) 2
29. If α and β are the roots of the equation $x^2 - x + 1 = 0$, then $\alpha^{2009} + \beta^{2009} =$
- (1) 2 (2) -2
 (3) -1 (4) 1
30. Consider the following relations :
 $R = \{(x, y) \mid x, y \text{ are real numbers and } x = wy \text{ for some rational number } w\};$
 $S = \{(\frac{m}{n}, \frac{p}{q}) \mid m, n, p \text{ and } q \text{ are integers such that } n, q \neq 0 \text{ and } qm = pn\}.$
 Then
- (1) R and S both are equivalence relations
 (2) R is an equivalence relation but S is not an equivalence relation
 (3) neither R nor S is an equivalence relation
 (4) S is an equivalence relation but R is not an equivalence relation

PART B – PHYSICS

31. A ball is made of a material of density ρ where $\rho_{\text{oil}} < \rho < \rho_{\text{water}}$ with ρ_{oil} and ρ_{water} representing the densities of oil and water, respectively. The oil and water are immiscible. If the above ball is in equilibrium in a mixture of this oil and water, which of the following pictures represents its equilibrium position?

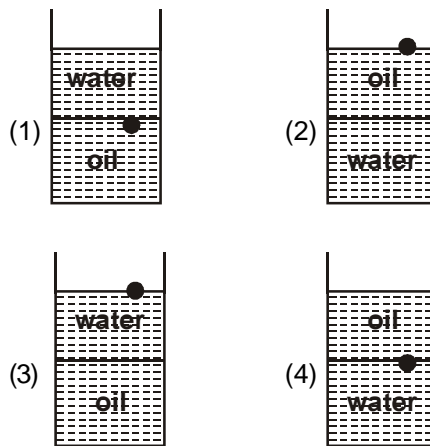

Directions : Questions number 32 – 33 are based on the following paragraph.

A nucleus of mass $M + \Delta m$ is at rest and decays into two daughter nuclei of equal mass $\frac{M}{2}$ each. Speed of light is c .

32. The speed of daughter nuclei is
- (1) $c\sqrt{\frac{\Delta m}{M}}$ (2) $c\sqrt{\frac{\Delta m}{M + \Delta m}}$
 (3) $c\frac{\Delta m}{M + \Delta m}$ (4) $c\sqrt{\frac{2\Delta m}{M}}$
33. The binding energy per nucleon for the parent nucleus is E_1 and that for the daughter nuclei is E_2 . Then
- (1) $E_2 > E_1$ (2) $E_1 = 2E_2$
 (3) $E_2 = 2E_1$ (4) $E_1 > E_2$

34. In series LCR circuit $R = 200\Omega$ and the voltage and the frequency of the main supply is 220 V and 50 Hz respectively. On taking out the capacitance from the circuit the current lags behind the voltage by 30° . On taking out the inductor from the circuit the current leads the voltage by 30° . The power dissipated in the LCR circuit is

- (1) Zero W (2) 242 W
 (3) 305 W (4) 210 W

35. Let there be a spherically symmetric charge distribution with charge density varying as

$$\rho(r) = \rho_0 \left(\frac{5}{4} - \frac{r}{R} \right) \text{ upto } r = R, \text{ and } \rho(r) = 0$$

for $r > R$, where r is the distance from the origin is given by

- (1) $\frac{4\rho_0 r}{3\epsilon_0} \left(\frac{5}{4} - \frac{r}{R} \right)$ (2) $\frac{\rho_0 r}{3\epsilon_0} \left(\frac{5}{4} - \frac{r}{R} \right)$
 (3) $\frac{4\pi\rho_0 r}{3\epsilon_0} \left(\frac{5}{3} - \frac{r}{R} \right)$ (4) $\frac{\rho_0 r}{4\epsilon_0} \left(\frac{5}{3} - \frac{r}{R} \right)$

Directions : Questions number 36 – 38 are based on the following paragraph.

An initially parallel cylindrical beam travels in a medium of refractive index $\mu(l) = \mu_0 + \mu_2 l$, where μ_0 and μ_2 are positive constants and l is the intensity of the light beam. The intensity of the beam is decreasing with increasing radius.

36. The speed of light in the medium is
 (1) directly proportional to the intensity l
 (2) maximum on the axis of the beam
 (3) minimum on the axis of the beam
 (4) the same everywhere in the beam

37. As the beam enters the medium, it will
 (1) diverge near the axis and converge near the periphery
 (2) travel as a cylindrical beam
 (3) diverge
 (4) converge

38. The initial shape of the wavefront of the beam is

- (1) convex near the axis and concave near the periphery
 (2) planar
 (3) convex
 (4) concave

39. A point P moves in counter-clockwise direction on a circular path as shown in the figure. The movement of 'P' is such that it sweeps out a length $s = t^3 + 5$, where s is in metres and t is in seconds. The radius of the path is 20 m. The acceleration of 'P' when $t = 2$ s is nearly

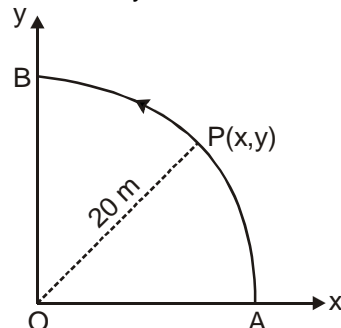

- (1) 7.2 m/s^2 (2) 14 m/s^2
 (3) 13 m/s^2 (4) 12 m/s^2

40. Two identical charged spheres are suspended by strings of equal lengths. The strings make an angle of 30° with each other. When suspended in a liquid of density 0.8 g cm^{-3} , the angle remains the same. If density of the material of the sphere is 1.6 g cm^{-3} , the dielectric constant of the liquid is

- (1) 2 (2) 1
 (3) 4 (4) 3

41. Two conductors have the same resistance at 0°C but their temperature coefficients of resistance are α_1 and α_2 . The respectively temperature coefficients of their series and parallel combinations are nearly

- (1) $\alpha_1 + \alpha_2, \frac{\alpha_1 \alpha_2}{\alpha_1 + \alpha_2}$ (2) $\frac{\alpha_1 + \alpha_2}{2}, \frac{\alpha_1 + \alpha_2}{2}$
 (3) $\frac{\alpha_1 + \alpha_2}{2}, \alpha_1 + \alpha_2$ (4) $\alpha_1 + \alpha_2, \frac{\alpha_1 + \alpha_2}{2}$

42. The potential energy function for the force between two atoms in a diatomic molecule is approximately given by $U(x) = \frac{a}{x^{12}} - \frac{b}{x^6}$, where a and b are constants and x is the distance between the atoms. If the dissociation energy of the molecule is $D = [U(x = \infty) - U_{\text{at equilibrium}}]$, D is
- (1) $\frac{b^2}{4a}$ (2) $\frac{b^2}{6a}$
 (3) $\frac{b^2}{2a}$ (4) $\frac{b^2}{12a}$

Directions : Questions number 43 – 44 contain Statement-1 and Statement-2. Of the four choices given after the statements, choose the one that best describes the two statements.

43. **Statement-1 :** When ultraviolet light is incident on a photocell, its stopping potential is V_0 and the maximum kinetic energy of the photoelectrons is K_{max} . when the ultraviolet light is replaced by X-rays, both V_0 and K_{max} increase.
Statement-2 : Photoelectrons are emitted with speeds ranging from zero to a maximum value because of the range of frequencies present in the incident light.
- (1) Statement-1 is true, Statement-2 is true.
 (2) Statement-1 is true, Statement-2 is false.
 (3) Statement-1 is true, Statement-2 is true; Statement-2 is the correct explanation of Statement-1.
 (4) Statement-1 is true, Statement-2 is true; Statement-2 is **not** the correct explanation of Statement-1.
44. **Statement-1 :** Two particles moving in the same direction do not lose all their energy in a completely inelastic collision.
Statement-2 : Principle of conservation of momentum holds true for all kinds of collisions.
- (1) Statement-1 is true, Statement-2 is true.
 (2) Statement-1 is true, Statement-2 is false.
 (3) Statement-1 is true, Statement-2 is true; Statement-2 is the correct explanation of Statement-1.

- (4) Statement-1 is true, Statement-2 is true; Statement-2 is **not** the correct explanation of Statement-1.

45. A radioactive nucleus (initial mass number A and atomic number Z) emits 3 α – particles and 2 positrons. The ratio of number of neutrons to that of protons in the final nucleus will be
- (1) $\frac{A - Z - 12}{Z - 4}$ (2) $\frac{A - Z - 4}{Z - 2}$
 (3) $\frac{A - Z - 8}{Z - 4}$ (4) $\frac{A - Z - 4}{Z - 8}$

46. If a source of power 4 kW produces 10^{20} photons/second, the radiation belongs to a part of the spectrum called
- (1) microwaves (2) γ – rays
 (3) X-rays (4) ultraviolet rays

47. The figure shows the position – time ($x - t$) graph of one-dimensional motion of a body of mass 0.4 kg. The magnitude of each impulse is

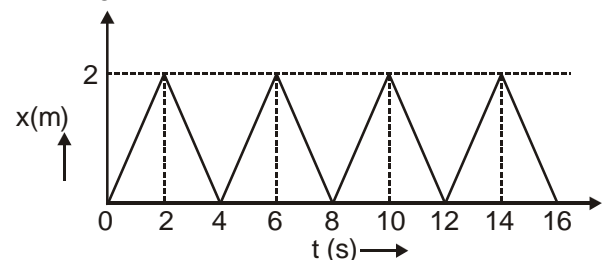

- (1) 1.6 Ns (2) 0.2 Ns
 (3) 0.4 Ns (4) 0.8 Ns

48. The combination of gates shown below yields

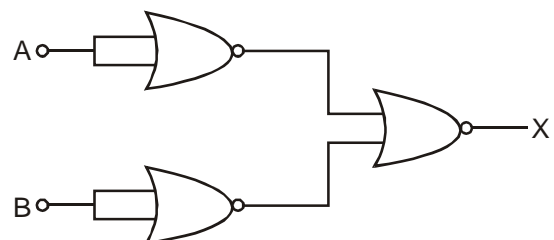

- (1) XOR gate (2) NAND gate
 (3) OR gate (4) NOT gate

49. Two long parallel wires are at a distance $2d$ apart. They carry steady equal currents flowing out of the plane of the paper as shown. The variation of the magnetic field B along the line XX' is given by

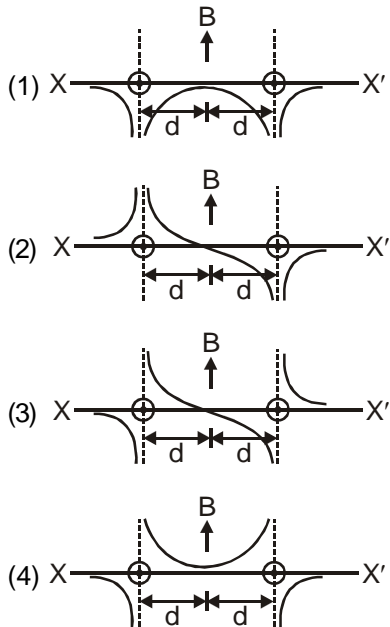

50. Let C be the capacitance of a capacitor discharging through a resistor R . Suppose t_1 is the time taken for the energy stored in the capacitor to reduce to half its initial value and t_2 is the time taken for the charge to reduce to one-fourth its initial value. Then the ratio t_1/t_2 will be

- (1) $\frac{1}{4}$ (2) 2
 (3) 1 (4) $\frac{1}{2}$

51. A rectangular loop has a sliding connector PQ of length l and resistance R_Ω and it is moving with a speed v as shown. The set-up is placed in a uniform magnetic field going into the plane of the paper. The three currents I_1 , I_2 and I are

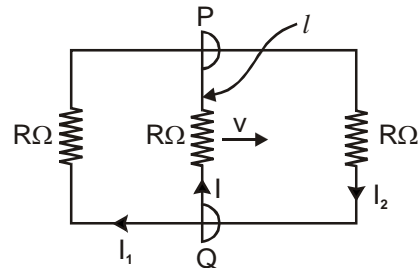

- (1) $I_1 = I_2 = I = \frac{B/v}{R}$
 (2) $I_1 = I_2 = \frac{B/v}{6R}, I = \frac{B/v}{3R}$
 (3) $I_1 = -I_2 = \frac{B/v}{R}, I = \frac{2B/v}{R}$
 (4) $I_1 = I_2 = \frac{B/v}{3r}, I = \frac{2B/v}{3R}$

52. For a particle in uniform circular motion, the acceleration \vec{a} at a point $P(R, \theta)$ on the circle of radius R is (Here θ is measured from the x -axis)

- (1) $-\frac{v^2}{R} \cos \theta \hat{i} - \frac{v^2}{R} \sin \theta \hat{j}$
 (2) $\frac{v^2}{R} \hat{i} + \frac{v^2}{R} \hat{j}$
 (3) $-\frac{v^2}{R} \cos \theta \hat{i} + \frac{v^2}{R} \sin \theta \hat{j}$
 (4) $-\frac{v^2}{R} \sin \theta \hat{i} + \frac{v^2}{R} \cos \theta \hat{j}$

53. Two fixed frictionless inclined planes making an angle 30° and 60° with the vertical are shown in the figure. Two blocks A and B are placed on the two planes. What is the relative vertical acceleration of A with respect to B?

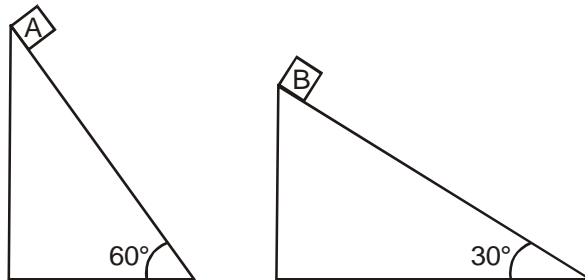

- (1) Zero
 (2) 4.9 ms^{-2} in vertical direction
 (3) 4.9 ms^{-2} in horizontal direction
 (4) 9.8 ms^{-2} in vertical direction
54. A small particle of mass m is projected at an angle θ with the x -axis with an initial velocity v_0 in the x - y plane as shown in the figure. At a time $t < \frac{v_0 \sin \theta}{g}$, the angular momentum of the particle is

At a time $t < \frac{v_0 \sin \theta}{g}$, the angular momentum of the particle is

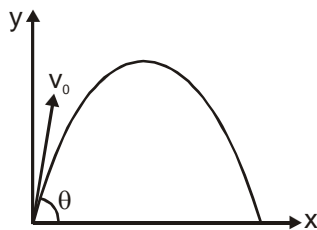

- (1) $-\frac{1}{2}mvv_0 t^2 \cos \theta \hat{k}$
 (2) $\frac{1}{2}mgv_0 t^2 \cos \theta \hat{i}$
 (3) $-mgv_0 t^2 \cos \theta \hat{j}$
 (4) $mgv_0 t \cos \theta \hat{k}$

where \hat{i} , \hat{j} and \hat{k} are unit vectors along x , y and z -axis respectively.

55. The equation of a wave on a string of linear mass density 0.04 kg m^{-1} is given by

$$y = 0.02(\text{m}) \sin \left[2\pi \left(\frac{t}{0.04(\text{s})} - \frac{x}{0.50(\text{m})} \right) \right]$$

The tension in the string is

- (1) 0.5 N (2) 6.25 N
 (3) 4.0 N (4) 12.5 N
56. A diatomic ideal gas is used in a Carnot engine as the working substance. If during the adiabatic expansion part of the cycle the volume of the gas increases from V to $32V$, the efficiency of the engine is
- (1) 0.99 (2) 0.25
 (3) 0.5 (4) 0.75
57. A thin semi-circular ring of radius r has a positive charge q distributed uniformly over it. The net field \vec{E} at the centre O is

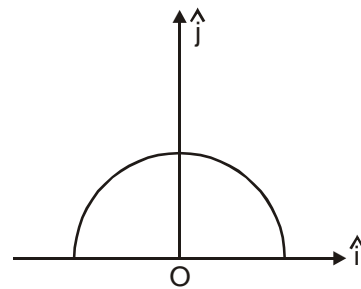

- (1) $-\frac{q}{2\pi^2 \epsilon_0 r^2} \hat{j}$ (2) $\frac{q}{2\pi^2 \epsilon_0 r^2} \hat{j}$
 (3) $\frac{q}{4\pi^2 \epsilon_0 r^2} \hat{j}$ (4) $-\frac{q}{4\pi^2 \epsilon_0 r^2} \hat{j}$
58. The respective number of significant figures for the numbers 23.023, 0.0003 and 2.1×10^{-3} are
- (1) 5, 5, 2 (2) 4, 4, 2
 (3) 5, 1, 2 (4) 5, 1, 5

59. A particle is moving with velocity

$$\vec{v} = K(\hat{y}\hat{i} + \hat{x}\hat{j}), \text{ where } K \text{ is a constant. The}$$

general equation for its path is

- (1) $xy = \text{constant}$
- (2) $y^2 = x^2 + \text{constant}$
- (3) $y = x^2 + \text{constant}$
- (4) $y^2 = x + \text{constant}$

60. In the circuit shown below, the key K is closed at $t = 0$. The current through the battery is

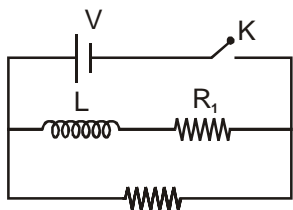

- (1) $\frac{V}{R_2}$ at $t = 0$ and $\frac{VR_1R_2}{\sqrt{R_1^2 + R_2^2}}$ at $t = \infty$
- (2) $\frac{V(R_1 + R_2)}{R_1R_2}$ at $t = 0$ and $\frac{V}{R_2}$ at $t = \infty$
- (3) $\frac{VR_1R_2}{\sqrt{R_1^2 + R_2^2}}$ at $t = 0$ and $\frac{V}{R_2}$ at $t = \infty$
- (4) $\frac{V}{R_2}$ at $t = 0$ and $\frac{V(R_1 + R_2)}{R_1R_2}$ at $t = \infty$

PART C – CHEMISTRY

61. A solution containing 2.675 g of $\text{CoCl}_3 \cdot 6\text{NH}_3$ (molar mass = 267.5 g mol^{-1}) is passed through a cation exchanger. The chloride ions obtained in solution were treated with excess of AgNO_3 to give 4.78 g of AgCl (molar mass = 143.5 g mol^{-1}). The formula of the complex is (At. mass of Ag = 108 u)
- (1) $[\text{CoCl}_3(\text{NH}_3)_3]$
 - (2) $[\text{CoCl}(\text{NH}_3)_5]\text{Cl}_2$
 - (3) $[\text{Co}(\text{NH}_3)_6]\text{Cl}_3$
 - (4) $[\text{CoCl}_2(\text{NH}_3)_4]\text{Cl}$
62. The standard enthalpy of formation of NH_3 is $-46.0 \text{ kJ mol}^{-1}$. If the enthalpy of formation of H_2 from its atoms is -436 kJ mol^{-1} and that of N_2 is -712 kJ mol^{-1} , the average bond enthalpy of N–H bond in NH_3 is
- (1) $+ 1056 \text{ kJ mol}^{-1}$
 - (2) $- 1102 \text{ kJ mol}^{-1}$
 - (3) $- 964 \text{ kJ mol}^{-1}$
 - (4) $+ 352 \text{ kJ mol}^{-1}$
63. The time for half life period of a certain reaction $\text{A} \rightarrow \text{Products}$ is 1 hour. When the initial concentration of the reactant 'A', is 2.0 mol L^{-1} , how much time does it take for its concentration to come from 0.50 to 0.25 mol L^{-1} if it is a zero order reaction?
- (1) 0.25 h
 - (2) 1 h
 - (3) 4 h
 - (4) 0.5 h
64. If sodium sulphate is considered to be completely dissociated into cations and anions in aqueous solution, the change in freezing point of water (ΔT_f), when 0.01 mol of sodium sulphate is dissolved in 1 kg of water, is ($K_f = 1.86 \text{ K kg mol}^{-1}$)
- (1) 0.0744 K
 - (2) 0.0186 K
 - (3) 0.0372 K
 - (4) 0.0558 K
65. From amongst the following alcohols the one that would react fastest with conc. HCl and anhydrous ZnCl_2 , is
- (1) 2-Methylpropanol
 - (2) 1-Butanol
 - (3) 2-Butanol
 - (4) 2-Methylpropan-2-ol

66. If 10^{-4} dm^3 of water is introduced into a 1.0 dm^3 flask at 300 K, how many moles of water are in the vapour phase when equilibrium is established?

(Given : Vapour pressure of H_2O at 300K is 3170 Pa; $R = 8.314 \text{ JK}^{-1} \text{ mol}^{-1}$)

- (1) $4.46 \times 10^{-2} \text{ mol}$ (2) $1.27 \times 10^{-3} \text{ mol}$
 (3) $5.56 \times 10^{-3} \text{ mol}$ (4) $1.53 \times 10^{-2} \text{ mol}$

67. In the chemical reactions,

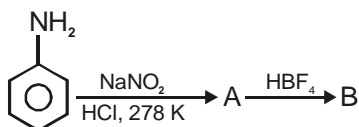

the compounds 'A' and 'B' respectively are
 (1) benzene diazonium chloride and fluorobenzene

- (2) nitrobenzene and chlorobenzene
 (3) nitrobenzene and fluorobenzene
 (4) phenol and benzene

68. Consider the following bromides :

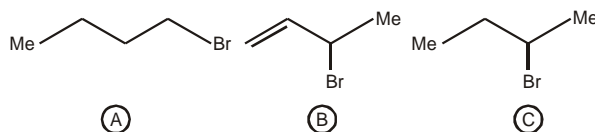

The correct order of $\text{S}_{\text{N}}1$ reactivity is

- (1) $\text{C} > \text{B} > \text{A}$ (2) $\text{A} > \text{B} > \text{C}$
 (3) $\text{B} > \text{C} > \text{A}$ (4) $\text{B} > \text{A} > \text{C}$

69. Which one of the following has an optical isomer?

- (1) $[\text{Co}(\text{H}_2\text{O})_4(\text{en})]^{3+}$ (2) $[\text{Zn}(\text{en})_2]^{2+}$
 (3) $[\text{Zn}(\text{en})(\text{NH}_3)_2]^{2+}$ (4) $[\text{Co}(\text{en})_3]^{3+}$
 (en = ethylenediamine)

70. The Gibbs energy for the decomposition of Al_2O_3 at 500°C is as follows :

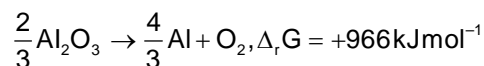

The potential difference needed for electrolytic reduction of Al_2O_3 at 500°C is at least

- (1) 2.5 V (2) 5.0 V
 (3) 4.5 V (4) 3.0 V

71. On mixing, heptane and octane form an ideal solution. At 373 K, the vapour pressures of the two liquid components (heptane and octane) are 105 kPa and 45 kPa respectively. Vapour pressure of the solution obtained by mixing 25.0 g of heptane and 35 g of octane will be (molar mass of heptane = 100 g mol^{-1} and of octane = 114 g mol^{-1})

- (1) 96.2 kPa (2) 144.5 kPa
 (3) 72.0 kPa (4) 36.1 kPa

72. The edge length of a face centered cubic cell of an ionic substance is 508 pm. If the radius of the cation is 110 pm, the radius of the anion is

- (1) 618 pm (2) 144 pm
 (3) 288 pm (4) 398 pm

73. The correct order of increasing basicity of the given conjugate bases ($R = \text{CH}_3$) is

- (1) $\text{RCOO}^- < \bar{\text{N}}\text{H}_2 < \text{HC} \equiv \bar{\text{C}} < \bar{\text{R}}$
 (2) $\text{RCOO}^- < \text{HC} \equiv \bar{\text{C}} < \bar{\text{N}}\text{H}_2 < \bar{\text{R}}$
 (3) $\text{RCOO}^- < \text{HC} \equiv \bar{\text{C}} < \bar{\text{R}} < \bar{\text{N}}\text{H}_2$
 (4) $\bar{\text{R}} < \text{HC} \equiv \bar{\text{C}} < \text{RCOO}^- < \bar{\text{N}}\text{H}_2$

74. For a particular reversible reaction at temperature T , ΔH and ΔS were found to be both positive. If T_e is the temperature at equilibrium, the reaction would be spontaneous when

- (1) T_e is 5 times T (2) $T = T_e$
 (3) $T_e > T$ (4) $T > T_e$

75. Consider the reaction :

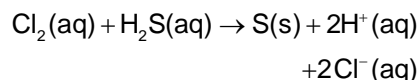

The rate equation for this reaction is

$$\text{rate} = k [\text{Cl}_2] [\text{H}_2\text{S}]$$

Which of these mechanisms is/are consistent with this rate equation?

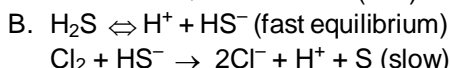
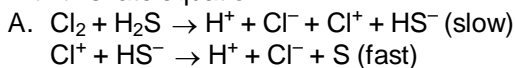

- (1) Neither A nor B (2) A only
 (3) B only (4) Both A and B

76. Percentages of free space in cubic close packed structure and in body centered packed structure are respectively
 (1) 32% and 48% (2) 48% and 26%
 (3) 30% and 26% (4) 26% and 32%
77. Out of the following, the alkene that exhibits optical isomerism is
 (1) 3-methyl-1-pentene
 (2) 2-methyl-2-pentene
 (3) 3-methyl-2-pentene
 (4) 4-methyl-1-pentene
78. One mole of a symmetrical alkene on ozonolysis gives two moles of an aldehyde having a molecular mass of 44 u. The alkene is
 (1) 2-butene (2) ethene
 (3) propene (4) 1-butene
79. 29.5 mg of an organic compound containing nitrogen was digested according to Kjeldahl's method and the evolved ammonia was absorbed in 20 mL of 0.1 M HCl solution. The excess of the acid required 15 mL of 0.1 M NaOH solution for complete neutralization. The percentage of nitrogen in the compound is
 (1) 23.7 (2) 29.5
 (3) 59.0 (4) 47.4
80. Ionization energy of He^+ is $19.6 \times 10^{-18} \text{ J atom}^{-1}$. The energy of the first stationary state ($n = 1$) of Li^{2+} is
 (1) $-2.2 \times 10^{-15} \text{ J atom}^{-1}$
 (2) $8.82 \times 10^{-17} \text{ J atom}^{-1}$
 (3) $4.41 \times 10^{-16} \text{ J atom}^{-1}$
 (4) $-4.41 \times 10^{-17} \text{ J atom}^{-1}$
81. The energy required to break one mole of Cl – Cl bonds in Cl_2 is 242 kJ mol^{-1} . The longest wavelength of light capable of breaking a single Cl – Cl bond is ($c = 3 \times 10^8 \text{ ms}^{-1}$ and $N_A = 6.02 \times 10^{23} \text{ mol}^{-1}$)
 (1) 700 nm (2) 494 nm
 (3) 594 nm (4) 640 nm
82. Solubility product of silver bromide 5.0×10^{-13} . The quantity of potassium bromide (molar mass taken as 120 g mol^{-1}) to be added to 1 litre of 0.05 M solution of silver nitrate to start the precipitation of AgBr is
 (1) $6.2 \times 10^{-5} \text{ g}$ (2) $5.0 \times 10^{-8} \text{ g}$
 (3) $1.2 \times 10^{-10} \text{ g}$ (4) $1.2 \times 10^{-9} \text{ g}$
83. The correct sequence which shows decreasing order of the ionic radii of the elements is
 (1) $\text{Na}^+ > \text{F}^- > \text{Mg}^{2+} > \text{O}^{2-} > \text{Al}^{3+}$
 (2) $\text{O}^{2-} > \text{F}^- > \text{Na}^+ > \text{Mg}^{2+} > \text{Al}^{3+}$
 (3) $\text{Al}^{3+} > \text{Mg}^{2+} > \text{Na}^+ > \text{F}^- > \text{O}^{2-}$
 (4) $\text{Na}^+ > \text{Mg}^{2+} > \text{Al}^{3+} > \text{O}^{2-} > \text{F}^-$
84. In aqueous solution the ionization constants for carbonic acid are $K_1 = 4.2 \times 10^{-7}$ and $K_2 = 4.8 \times 10^{-11}$. Select the correct statement for a saturated 0.034 M solution of the carbonic acid.
 (1) The concentrations of H^+ and HCO_3^- are approximately equal.
 (2) The concentration of H^+ is double that of CO_3^{2-}
 (3) The concentration of CO_3^{2-} is 0.034 M
 (4) The concentration of CO_3^{2-} is greater than that of HCO_3^-
85. At 25°C , the solubility product of $\text{Mg}(\text{OH})_2$ is 1.0×10^{-11} . At which pH, will Mg^{2+} ions start precipitating in the form of $\text{Mg}(\text{OH})_2$ from a solution of 0.001 M Mg^{2+} ions?
 (1) 11 (2) 8
 (3) 9 (4) 10
86. The polymer containing strong intermolecular forces e.g. hydrogen bonding, is
 (1) polystyrene (2) natural rubber
 (3) teflon (4) nylon 6, 6

87. The main product of the following reaction is

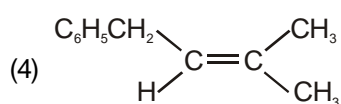
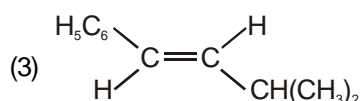
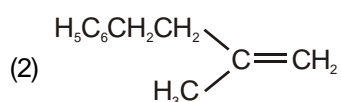
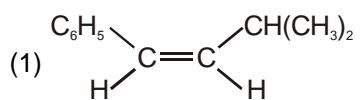
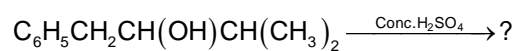

88. Biuret test is **not** given by

- (1) urea (2) proteins
(3) carbohydrates (4) polypeptides

89. The correct order of $E_{\text{M}^{2+}/\text{M}}^\circ$ values with negative sign for the four successive elements Cr, Mn, Fe and Co is

- (1) Fe > Mn > Cr > Co
(2) Cr > Mn > Fe > Co
(3) Mn > Cr > Fe > Co
(4) Cr > Fe > Mn > Co

90. Three reactions involving H_2PO_4^- are given below :

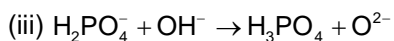
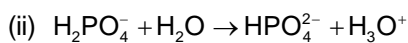
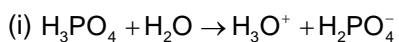

- (1) (iii) only (2) (i) only
(3) (ii) only (4) (i) and (ii)